

# Ascotel *Office Terminals* by **ascom**

## **Office 100**

Bedienungsanleitung  
Mode d'emploi  
Istruzioni per l'uso  
Operating instructions

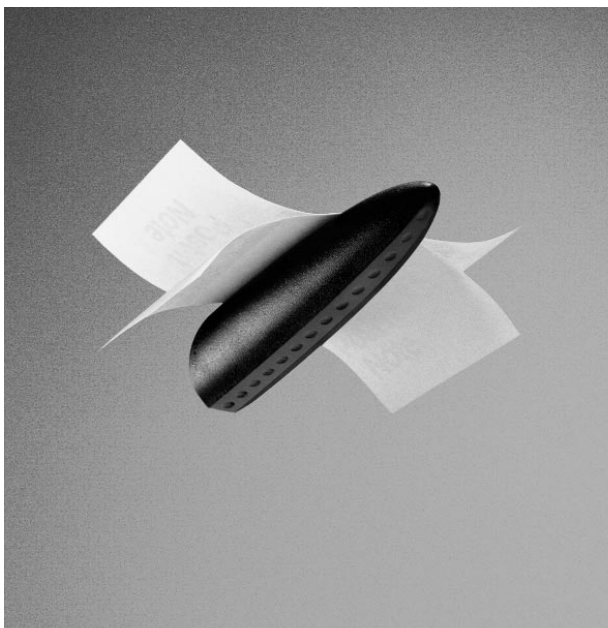



## *Herzliche Gratulation!*

Herzliche Gratulation zu Ihrem Ascom Office 100 Funktelefon. Dieses Handgerät verleiht Ihnen die gewünschte Bewegungsfreiheit. Die Digitaltechnik des Office 100 gewährleistet eine ausgezeichnete Sprachqualität, und das kleine Handgerät bietet Ihnen einen vergleichbaren Telefonkomfort wie ein stationäres Ascom Office 30.

## *Toutes nos félicitations!*

Nous vous félicitons sincèrement pour l'achat de votre téléphone sans fil Ascom Office 100. Cet appareil portatif vous procure une liberté de mouvement bienvenue. Grâce à sa technique numérique, l'Office 100 procure une excellente qualité de conversation. De surcroît, le petit appareil portatif vous offre un confort téléphonique comparable à celui d'un Ascom Office 30 fixe.

## *Congratulazioni!*

Congratulazioni per l'acquisto del vostro nuovo telefono cordless Ascom Office 100. Questo pratico apparecchio vi offre la mobilità desiderata e, malgrado le sue dimensioni compatte, con la sua tecnica digitale garantisce una trasmissione eccellente della voce e un comfort paragonabile a quello di un modello da tavolo Ascom Office 30.

## *Congratulations!*

Congratulations on the purchase of your Ascom Office 100. This handset affords you the freedom of movement you desire. The digital technology of the Office 100 guarantees excellent speech quality, and the small handset offers you telephony comfort comparable to a stationary Ascom Office 30.

## **Inhalt**

Bedienungs- und Anzeigeelemente.....	1
Das Bedienkonzept: die Menütechnik.....	3
Sicherheitshinweise.....	4
Installation und Inbetriebnahme .....	6
Bevor Sie das erste Mal telefonieren .....	9
So telefonieren Sie.....	11
So benutzen Sie die Komfortfunktionen ...	15
So programmieren Sie Ihren Apparat.....	21
Störungen .....	36
Funktionscodes.....	37
Index .....	41

## **Table des matières**

Éléments de desserte et d'affichage.....	1
Concept d'utilisation: la technique à menus .....	3
Consignes de sécurité.....	4
Installation et mise en service .....	6
Avant de téléphoner pour la première fois ...	9
Pour téléphoner.....	11
Pour utiliser les fonctions de confort.....	15
Pour programmer l'appareil .....	21
Dérangements.....	36
Codes de fonction .....	37
Index .....	41

## **Indice**

Comandi e visualizzazioni.....	1
Il metodo di comando: la tecnica a menu...3	3
Avvertenze di sicurezza.....	4
Installazione e messa in servizio .....	6
Prima di telefonare la prima volta .....	9
Come telefonare.....	11
Per usare le funzioni comfort.....	15
Come programmare il vostro apparecchio.....	21
Malfunzionamenti .....	36
Codici di funzione .....	37
Indice analitico .....	41

## **Contents**

Operation and display elements.....	1
Operation: the menu system .....	3
Safety Advice.....	4
Installation and putting into service .....	6
Before you telephone for the first time.....	9
Telephoning.....	11
Using the extended-feature functions.....	15
Programming your telephone .....	21
Troubleshooting.....	36
Function codes .....	37
Index .....	41

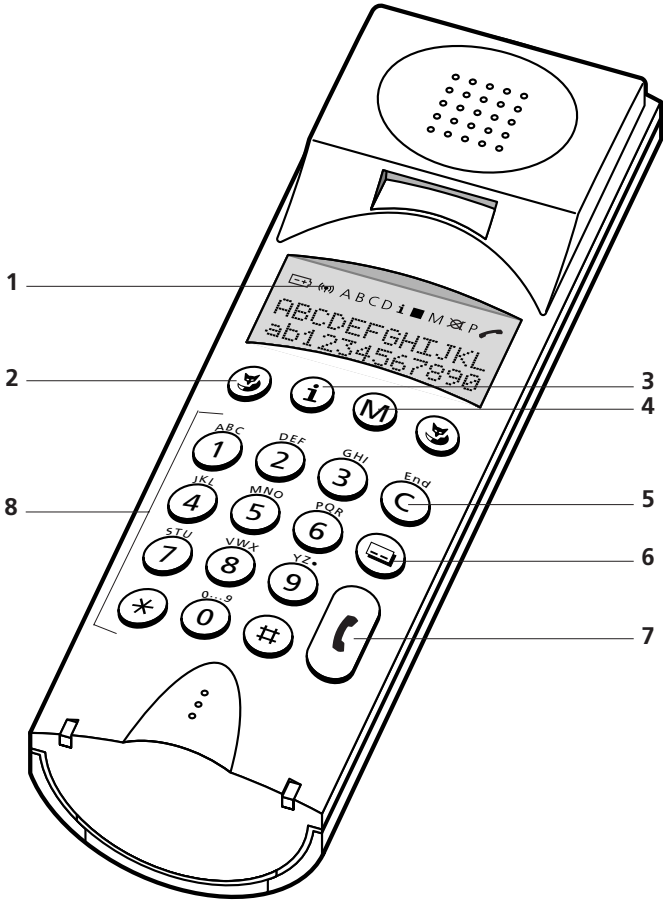

# Bedienungs- und Anzeigeelemente

## 1 Anzeigefeld (Display)

Das Display umfasst die Symbol-, die Informations- und die Menüzeile mit je 12 Symbolen/Zeichen:

## 2 Foxtasten

In der untersten Display-Zeile wird die jeweilige Funktion angezeigt. Beide Foxtasten sind frei programmierbar.

## 3 i-Taste (Info-Taste)

Zur Abfrage weiterer Informationen (i-Symbol aktiv)

## 4 M-Taste (Menü-Taste)

Dient zur Suche des gewünschten Menüpunktes; wirkt zyklisch, d.h. nach dem letzten Menüpunkt einer Liste wird wieder der erste angezeigt (M-Symbol aktiv).

## 5 C-/End-Taste (Lösch- oder Korrekturtaste)

Lösch- oder Korrekturtaste (Clear) bei der Zeicheneingabe. Rückkehr zum vorherigen Menüpunkt oder in den Ruhezustand.

## 6 Hotkey

Frei programmierbare Taste für bis zu 6 Nummern/Namen oder Funktionen

## 7 Gesprächstaste

Gleiche Wirkung wie das Abheben/Auflegen des Hörers. Wieder einschalten des ausgeschalteten Handgeräts.

## 8 Tastenblock 0 bis 9 (A bis Z), \* und #

Zifferneingabe und Wahl von Komfortfunktionen mit \*/#-Prozeduren. Eingabe von Namen und/oder Texten im Alpha-Modus. (Die Umschaltung von Ziffern auf Buchstaben erfolgt autom. nach der Wahl eines entsprechenden Menüpunktes.)

Beispiel: 1x Taste 2 = D, 2x Taste 2 = E, 3x Taste 1 = C, 2x Taste 7 = T

Im Alpha-Modus kann die #-Taste auch einen Leerschlag erzeugen.



## Besondere Display-Symbole



Ladezustand der Akkus

Keine Anzeige: Ladezustand gut, Handgerät betriebsbereit

Blinkende Anzeige: Ladezustand tief (Warnung)

Blinkend + Warnton: Ladezustand sehr tief



Antennensymbol

Keine Anzeige:

Ausserhalb des Empfangs-/Sendebereichs

Daueranzeige:

Bereit für ankommende und abgehende Verbindungen.

A (B,C,D)

Daueranzeige:

Handgerät im System A (B,C oder D) angemeldet und betriebsbereit.

Blinkend:

Handgerät nicht betriebsbereit.

ABCD

Blinkend:

Handgerät ist in keinem System angemeldet.

ABC

Daueranzeige:

Alpha-Wahl aktiv



Zusatzinformation (mit i-Taste abfragen)



Eine unter dem Hotkey/der Foxtaste gespeicherte Funktion ist aktiv

M

Weitere Menüs (mit M-Taste ansteuern)



Mikrofon ausgeschaltet

P

Programmier-Modus



Daueranzeige:

Verbindung aufgebaut

Blinkend:

Optische Signalisierung eines Anrufs

Weitere Symbole auf Informations- oder Menüzeile:

12☒ "Blättern" durch eine Liste (mit Laufnummer des Eintrags)

S Anruf auf Sammelanschluss (Teilnehmergruppe)

U Umgeleiteter Anruf

√ Funktion ist aktiv

Qualität der Funkverbindung (nur im Ruhe-Display)

■■■■■■■ Sehr gute Verbindungsqualität

■■■■■ Gute Verbindungsqualität

■■■■ Telefonieren möglich, Störungen wahrscheinlich

■■■ Telefonieren nur bedingt möglich, starke Einschränkungen

■■■■ Telefonieren nicht mehr möglich

### **Hinweis**

Die Verbindungsqualität kann auch mit "Long Click 4" abgefragt werden. Gleichzeitig wird die Nummer der betreffenden Funkeinheit angezeigt.

# Das Bedienkonzept: die Menütechnik

Sie können das Handgerät Ihren Bedürfnissen entsprechend programmieren. Es bietet Ihnen, neben der Mobilität, alle Telefoniefunktionen die Sie sich wünschen können. Trotzdem ist es einfach und leicht (intuitiv) zu bedienen; dafür sorgen die durchdachte Menütechnik und die Foxtasten. Das Kapitel "So programmieren Sie Ihren Apparat" und die Programmieranleitung helfen Ihnen, die Leistungsmerkmale Ihres Handgeräts voll auszuschöpfen.

## Allgemeine Bedienregeln

Es gibt zwei Menüarten:

- Die alltäglich gebrauchten Bedienmenüs für Telefoniefunktionen.
- Die Programmiermenüs, zur Einstellung Ihres Geräts, gemäss Ihren Bedürfnissen.

**Ruhe-Display** Im Ruhezustand sind im Display einige Symbole, die Qualitätsanzeige sowie Datum und Uhrzeit oder ein individueller Ruhetext (z.B. Name, Abteilung, Tel.Nr. etc.) zu sehen. Bei einem Anruf oder in der Gesprächsphase wechselt die Anzeige automatisch zum Menü "Diskret" bzw. zu "Rückfragen" "Mikro".

→ → → Mit der M-Taste (einmal oder mehrmals kurz drücken) gelangen Sie zu dem gewünschten Bedienmenü.

→ Ein "Long Click" der M-Taste (min. 2 Sekunden) bewirkt einen Sprung in den Programmiermodus.

→ Ein "Long Click" der Foxtaste unter "☼" ändert die Suchrichtung in "☼".

Ruhezustand  
Mit M-Taste das gewünschte Menü aufrufen

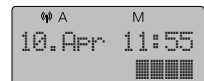

**M** M-Taste einmal drücken

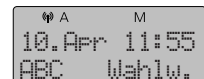

**M** M-Taste ein zweites Mal drücken

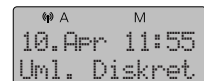

**M** M-Taste ein drittes Mal drücken

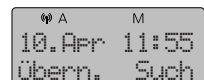

**M** M-Taste ein viertes Mal drücken

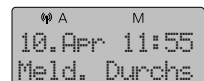

**M** M-Taste ein fünftes Mal drücken

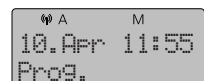

# Sicherheitshinweise

Lesen Sie bitte die Bedienungsanleitung und bewahren Sie diese auf. Bitte studieren Sie die hier aufgeführten Sicherheitshinweise gründlich. Die Nichtbeachtung dieser Richtlinien kann Gefahren verursachen und gegen bestehende Gesetze verstossen.



## Medizinische Geräte

Das Telefon sollte nicht in der Nähe von persönlichen medizinischen Geräten wie Herzschrittmachern oder Hörgeräten eingesetzt werden.



## Verfügbarkeit der Telefonverbindung

Die Verfügbarkeit des Funkeinheiten-Netztes ist nicht immer gewährleistet. Verlassen Sie sich in kritischen Situationen nicht auf das Mobiltelefon als einziges Kommunikationsmittel.



## Umgebungsbedingungen

Betreiben Sie Ihr Gerät nur im Temperaturbereich von +5 °C bis ca. +35 °C. Vermeiden Sie direkte Sonnenbestrahlung und andere Wärmequellen.



Schützen Sie Ihren Apparat vor Nässe, starkem Staub, aggressiven Flüssigkeiten und Dämpfen.

Setzen Sie Ihren Apparat nicht elektromagnetischen Feldern (Elektromotoren, Haushaltgeräten) aus. Die Sprachqualität könnte beeinträchtigt werden. Vermeiden Sie einen Standort in unmittelbarer Nähe von Computer, Radio-, TV-, Video-geräten und anderen Telefonapparaten, um Störungen zu vermeiden.



Benutzen Sie Ihr Gerät nicht in explosionsgefährdeten Räumen.



Benutzen Sie das Telefon nicht in der Nähe von Sprengarbeiten. Beachten Sie die Einschränkungen und halten Sie sich an die einschlägigen Vorschriften.



## Wartung

Verwenden Sie ausschliesslich Originalzubehör. Installationen und Reparaturen sind immer durch den dafür qualifizierten Fachmann ausführen zu lassen. Berühren Sie die Ladekontakte nicht mit spitzen, metallischen und/oder fettigen Gegenständen.

Reinigen Sie Ihr Gerät mit einem weichen, leicht feuchten oder antistatischen Tuch. Verwenden Sie keine Reinigungsmittel oder andere chemischen Substanzen.

# Sicherheitshinweise

## Wichtige Information

Damit niemand mit anderen Handgeräten auf Ihre Kosten telefonieren kann, findet zwischen Funkeinheit und Handgerät ständig ein Kennungsaustausch statt. Stimmen die Kennungen nicht überein, wird die Verbindung abgebrochen bzw. gar nicht erst aufgebaut.

## Tastatur sperren/entsperren

Ihr Handgerät können Sie gegen das versehentliche Betätigen von Tasten sperren. Anrufe können Sie trotzdem mit der Gesprächstaste entgegennehmen. Vor abgehenden Gesprächen ist die Tastatur zu entsperren.

## Code/Passwort ändern

Nach dem erstmaligen Einschalten des Handgeräts hat der Code/das Passwort den Wert "0000". Es wird empfohlen, sofort eine persönliche Kennzahl aus 2 bis 10 Ziffern zu definieren, um die persönliche Einstellung Ihres Handgeräts und die darin gespeicherten Daten vor unbefugter Benutzung zu schützen.

## Akkus

Im Lieferumfang des Gerätes sind zwei wiederaufladbare NiMh-Akkus der Bauform AA (Mignonzellen) enthalten.

- Der Einsatz anderer Akkuzellen-Typen oder von nicht wiederaufladbaren Batterien/ Primärzellen kann gefährlich sein und zusätzlich zu Funktionsstörungen des Gerätes bzw. Beschädigungen führen.
- Richtige Einbaulage der Akkuzellen beachten!
- Akkuzellen nicht ins Wasser tauchen, auch nicht ins Feuer werfen.
- Für die Lademulde nur das mitgelieferte Steckernetzgerät verwenden.
- Vor der Erstinbetriebnahme müssen die Akkuzellen mindestens 9 Stunden ohne Unterbrechung aufgeladen werden.

## Hinweise

- Akkuzellen können während des Aufladens warm werden; dies ist ein normaler und ungefährlicher Vorgang.
- Die Akkuzellen erreichen erst nach einigen Tagen Gebrauch ihre volle Kapazität und damit auch die volle "Bereitschafts- und Gesprächszeit".

Bei längerer Ausserbetriebnahme durch Stromabschaltung (z.B. bei Urlaub), ist das Handgerät (bzw. die Akkuzellen) vor Wieder-Inbetriebnahme zu laden.

Defekte Akkuzellen bitte der richtigen Entsorgung zuführen (kein Hausmüll).

# Installation und Inbetriebnahme

## Verpackungsinhalt

In der Verpackung des Gerätes sind enthalten:

- Lademulde
- Handgerät
- Clip
- 2 Akkuzellen
- Steckernetzgerät
- Bedienungsanleitung

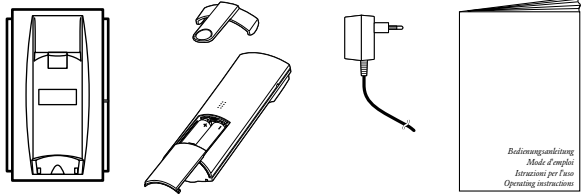

## Steckernetzgerät anschliessen

Führen Sie das Kabel durch die dafür vorgesehene Zugschleife.

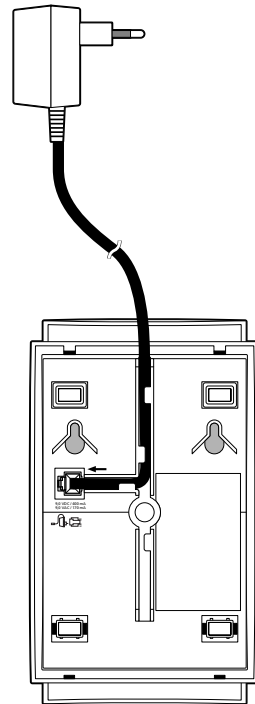

# Installation und Inbetriebnahme

## Tisch oder Wand, wie Sie wollen

### Tischversion

Am einfachsten verwenden Sie das Gerät als Tischgerät. Dazu müssen Sie das Gerät nur am gewünschten Ort aufstellen und anschliessen.

### Wandversion

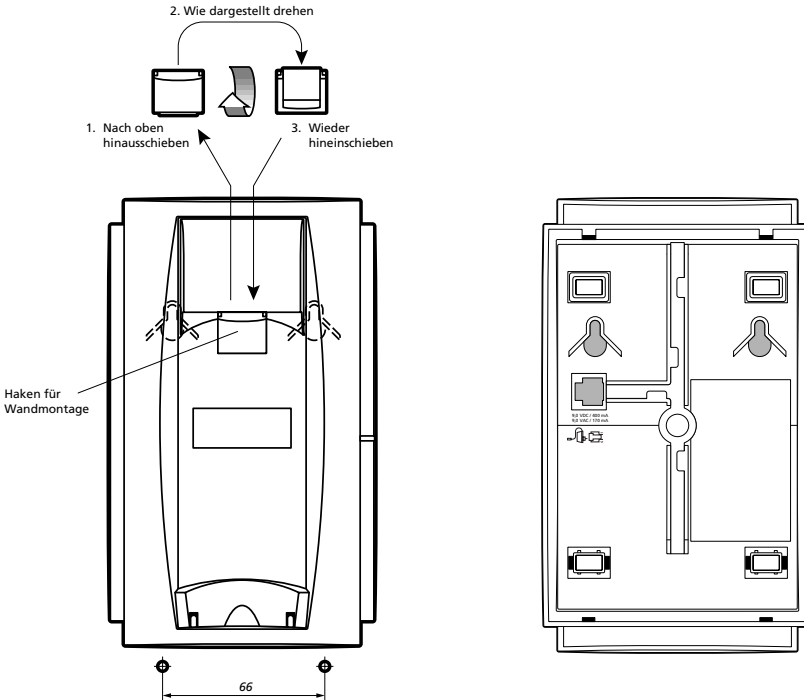

1. Drehen sie den Wandmontagehaken in der Lademuße um 180° (gemäss Abbildung).
2. Tauschen Sie die Füße an der Rückseite der Lademuße (hohe Füße unten), damit diese parallel zur Wand hängt.
3. Bohren Sie zwei Dübellöcher (Durchmesser 5 mm) im Abstand von 66 mm.
4. Setzen Sie die Dübel ein.
5. Schrauben Sie die beiden Schrauben soweit ein, bis die Schraubenköpfe einen Abstand von ca. 5 mm zur Wand haben.
6. Hängen Sie die Lademuße ein, und ziehen Sie diese ein wenig nach unten.

# Installation und Inbetriebnahme

## Einsetzen und Laden der Akkuzellen im Handgerät

### Akkuzellen einsetzen

1. Entfernen Sie den Akkufach-Deckel des Handgerätes, indem Sie ihn durch leichtes Andrücken nach unten schieben.
2. Legen Sie die 2 Akkuzellen in das Akkufach (gemäß Abbildung). Achten Sie auf die richtige Polung der Akkuzellen, sie ist auch im Akkufach angegeben.
3. Schieben Sie den Akkufach-Deckel über die Akkuzellen und verschliessen Sie das Fach. Der Deckel rastet hörbar ein.

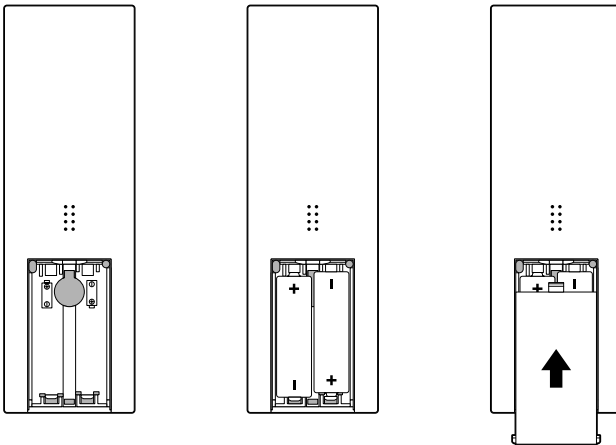

### Laden der Akkuzellen

Im Lieferzustand sind die Akkuzellen nicht geladen. Zum Laden muss das Handgerät in die Lademuße gelegt werden.

Die Leuchtanzeige (grüne LED) an der Lademuße

- blinkt = Akkuzellen werden geladen
- leuchtet = Akkuzellen sind geladen

Eine Akkuladung (1100 mAh-NiMH) reicht für	ca. 60	Stunden "Bereitschaft" bzw.
	ca. 8	Stunden "Telefonieren"
Die Ladezeit beträgt	ca. 9	Stunden

### Hinweis

Mit "Long Click 6" kann der Akku-Typ und der Ladezustand angezeigt werden. Nach dem Auswechseln der Akkus erhält man erst nach 10-15 Minuten Ladezeit eine verlässliche Angabe über den Ladezustand.

# Bevor Sie das erste Mal telefonieren

## Display-Sprache einstellen

Normalerweise ist die im Verkaufsgebiet gesprochene Sprache eingestellt. Falls Sie eine andere Sprache bevorzugen, können Sie unter mehreren Sprachen wählen.

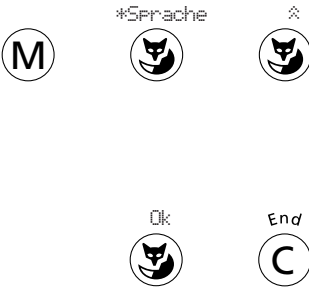

Im Programmiermodus M-Taste so oft drücken bis "**\*Sprache**" erscheint (achten Sie dabei auf das "\*" -Zeichen bei einer Fremdsprache). Mit Foxtaste unter "**Sprache**" die aktuelle Sprache aufrufen. Foxtaste unter "\*" so oft drücken bis die gewünschte Sprache angezeigt wird.

Mit Foxtaste unter "**Ok**" gewählte Sprache bestätigen. Mit der C-/End-Taste gelangt man wieder in den Ruhezustand.

## An PBX-System anmelden

Sie können Ihr Handgerät an bis zu 4 verschiedenen PBX-Systemen (A, B, C, D) anmelden. Somit sind Sie auch dann via Ihr Handgerät erreichbar, wenn Sie sich in einer Filiale Ihrer Firma aufhalten.



Im Programmiermodus M-Taste so oft drücken bis "**System**" erscheint. Foxtaste unter "**System**" drücken. Im Display wird "**Auto**" oder das aktuelle System (A, B, C oder D) angezeigt.

M-Taste drücken. Erscheint beispielsweise "**Anmelden: A**" und "**Löschen**", so ist das Handgerät am PBX-System "**A**" angemeldet (mit der Foxtaste unter "**Löschen**" könnte die Anmeldung gelöscht werden).

Mit der Foxtaste unter "\*" kann das Handgerät an drei weiteren PBX-Systemen (B, C oder D) angemeldet werden. Die Anzeige wechselt dann auf "**Anmelden: B (C oder D)**" und "**Neu**". Mit der Foxtaste unter "**Neu**" und "**Home**" wird das Handgerät an System "**B**" angemeldet (sofern dieses verfügbar und erlaubt ist).

# Bevor Sie das erste Mal telefonieren

Neu



GAP



Mit einem "Authentication Code" kann das Handgerät auch an einem fremden PBX-System mit GAP (Generic Access Profile) angemeldet werden.

Foxtaste unter "Neu" und "GAP" drücken, nach "AC: \_\_\_\_" den Authentication Code eingeben und mit Foxtaste unter "Ok" bestätigen.

Ok



## GAP-Anmeldung, Kompatibilität mit anderen DECT-Produkten

Ascotel DECT unterstützt alle Basis-Telefonie-Leistungsmerkmale, wie sie im Standard des Generic Access Profile (GAP) definiert sind (Ausgabe Ende 1997). Hierzu gehören Auf- und Abbau abgehender und ankommender Verbindungen, Rückfrage, Frequenzwahl (DTMF) und \*/#-Prozeduren. Das heisst:

- Ihr DECT-Systemendgerät kann in PBX anderer Hersteller angemeldet und verwendet werden. Voraussetzung für die Nutzung aller im GAP-Standard definierten Basis-Leistungsmerkmale ist, dass diese in der betreffenden PBX voll implementiert sind.
- DECT-Handgeräte anderer Hersteller, die den GAP-Standard erfüllen, können auch in Ihrer Anlage angemeldet und verwendet werden. Sie bieten aber nur die durch den GAP-Standard eingeschränkte Funktionalität und nicht die gleiche Qualität der Funkverbindung. Insbesondere die SW für das Mobility Management mit Handover/ Roaming ist nahezu zu 100% vom benutzten Handgeräte abhängig und kann nicht optimal auf Ihre Anlage abgestimmt sein.

## PBX-System einstellen



System



Im Programmiermodus M-Taste so oft drücken bis "System" erscheint. Foxtaste unter "System" drücken. Im Display wird "Auto" oder das aktuelle System (A, B, C oder D) angezeigt.



Ok



Mit der Foxtaste unter "☼" das gewünschte System oder "Auto" wählen und mit "Ok" bestätigen. (Wenn mehr als 1 System verfügbar ist, nimmt das Handgerät bei "Auto" autom. die Verbindung zu dem System mit der besten Funkverbindung auf).

## Hinweise

- Mit "Long Click 1" (min. 2 Sekunden) kann das Handgerät auf das nächste verfügbare PBX-System (A, B, C oder D) umgeschaltet werden. Sofern die Umschaltung nicht auf "Auto" steht, ist die manuelle Umschaltung des PBX-Systems zwingend, damit Ihr Handgerät im neuen PBX-System funktionsbereit ist.
- Mit "Long Click 2" erfolgt die Anzeige der International Portable Equipment Identity (IPEI) und des PARK (Portable Access Right Key).
- Mit "Long Click 5" erfolgt die Anzeige der SW-Versionnummer des Handgeräts mit Datum.

# So telefonieren Sie

## Anruf entgegennehmen

Auf dem Handgerät wird ein Anruf signalisiert.



Befindet sich das Handgerät ausserhalb der Lademulde, beantworten Sie den Anruf durch drücken der Gesprächstaste.

oder

Das Handgerät befindet sich in der Lademulde. Der Anruf wird beim Herausnehmen direkt beantwortet (siehe "So programmieren Sie Ihren Apparat", "Direkt beantworten").

## Anruf übernehmen

Unter "Übernehmen" bietet Ihnen das System die Menüpunkte "Teilnehmer (TIn)", "Zentralwecker/Ringsignal (Ring)" und "Personensuchanlage (Such)" an. Um zum Beispiel einen Anruf zu einem Anschluss eines anderen gerade abweseneden Teilnehmers mit Ihrem Handgerät zu beantworten, ist die M-Taste so oft zu drücken bis "Übernehmen" erscheint. Die Foxtaste an dieser Stelle drücken, "Teilnehmer" wählen und die Nummer des gerufenen Anschlusses eingeben, um den Anruf zu beantworten.

## Gespräch

Während eines Gesprächs können Sie mit der M-Taste weitere Funktionen ausführen, wie z.B. eine Rückfrage einleiten, das Mikrofon ausschalten ("Mic mute"), die Lautstärke im Hörer von "Leise" auf "Laut" (oder umgekehrt) schalten.



M-Taste ein oder mehrmals drücken, um weitere Funktionen auszuführen.

## Gespräch beenden

Ein Gespräch wird durch das Drücken der Gesprächstaste oder durch das Zurücklegen des Handgerätes in die Lademulde beendet. Selbstverständlich kann auch der Gesprächspartner die Verbindung beenden. Das Handgerät nimmt kurze Zeit danach den Ruhezustand ein.

## Hörerlautstärke während eines Gesprächs einstellen

Wenn Sie Ihren Gesprächspartner schlecht verstehen, weil der Geräuschpegel in Ihrer Umgebung zu hoch ist, können Sie die Hörerlautstärke auf "Laut" stellen.



M-Taste so oft drücken bis "Laut" erscheint. Foxtaste unter "Laut" drücken.

## Hinweis

Die vorgenommene Einstellung bleibt auch nach Gesprächsende unverändert.

# So telefonieren Sie

## Wählen mit Wahlvorbereitung

Die Wahlvorbereitung verringert die Gefahr von falschen Verbindungen. Ohne vorher die Gesprächstaste zu drücken, die gewünschte Nummer eingeben. Eingabe überprüfen und eventuell mit C-Taste korrigieren. Gesprächstaste drücken, erst jetzt wird der betreffende Anschluss gerufen.

## Ziffernwahl

Dies entspricht dem gewohnten Wahlvorgang, der Verbindungsaufbau wird aber erst mit dem Drücken der Gesprächstaste eingeleitet.



Ziffern eingeben und Gesprächstaste drücken.

## Wahlwiederholung

Im Wahlwiederholungsspeicher befinden sich die Nummern und evtl. die Namen der 10 zuletzt gerufenen Teilnehmer.



Wahlw.



M-Taste drücken.  
Foxtaste unter "Wahlwiederholung" drücken.  
Die Nummer und eventuell der Name des zuletzt gerufenen Teilnehmers wird angezeigt.

\*



Foxtaste unter "\*" so oft drücken bis die gewünschte Teilnehmernummer erscheint.  
Gesprächstaste drücken.

## Hinweis

Das i-Symbol verweist auf Zusatzinformation. Sie kann mit der i-Taste abgefragt werden.

## Wahl mit Hotkey

Unter dem Hotkey können bis zu 6 Namen/Nummern von Teilnehmern abgelegt werden, mit denen Sie häufig telefonieren.

Meier



Den Hotkey so oft drücken bis der gewünschte Name angezeigt wird.



Foxtaste unter dem betreffenden Namen und danach Gesprächstaste drücken.

# So telefonieren Sie

## Wahl mit Namen aus einer Kartei

Es gibt bis zu drei Telefonverzeichnisse (Karteien); ein internes Verzeichnis (mit allen an der PBX angeschlossenen Teilnehmern), eine Liste mit Kurzwahlnummern und eine Privatkartei. Mit dem Teilnehmernamen kann die gewünschte Verbindung aufgebaut werden, ohne die zugehörige Nummer einzugeben.

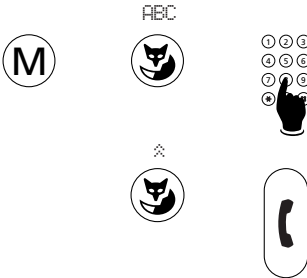

M-Taste drücken. Foxtaste unter ABC drücken; es erscheint das Menü für die Wahl der Kartei. ("Alle" sucht in allen Karteien).

Die Initialen von Nachnamen und Vornamen eingeben, - z.B. E # A für Einstein Albert.

Mit Foxtaste unter "☼" bis zum gewünschten Namen blättern und mit der Gesprächstaste den Wahlvorgang starten.

### Hinweis

Die Eingabe der Initialen ist die einfachste Art, eine in einer Kartei gespeicherte Nummer zu wählen; Sie brauchen weder die Telefon- noch eine Kurzwahlnummer zu kennen.

Beispiel:

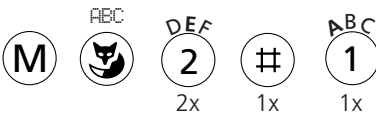

Einstein Albert:  
Taste 2: zweimal  
#-Taste: einmal (erzeugt ein Leerzeichen.)  
Taste 1: einmal

Wenn nur der Nachname bekannt ist:



In Wahlvorbereitung eingegebene Nummern oder Namen korrigieren Sie mit der Korrekturtaste (letztes Zeichen löschen).



Ein "Long Click" der C-Taste beendet eine begonnene Wahlvorbereitung.



Natürlich können Sie mit Ihrem Handgerät auch auf herkömmliche Art wählen: Gesprächstaste drücken und Nummer wählen.

Warten Sie bei der Eingabe zwischen zwei Ziffern mehr als 10 Sekunden, wird die Wahl automatisch abgebrochen.

# So telefonieren Sie

## Anrufliste

Ihr Handgerät speichert automatisch die Nummern der letzten 10 unbeantworteten Anrufe in der Anrufliste. Das i-Symbol im Display macht Sie auf die unbeantworteten Anrufe aufmerksam. Sie können die Nummern abfragen und die entsprechenden Personen über diese Liste zurückrufen.



Anrufliste



i-Taste so oft drücken bis "Anrufliste" erscheint. Foxtaste unter "Anrufliste" drücken und mit Foxtaste unter "❄" bis zur gewünschten Nummer blättern.



Löschen



Gesprächstaste drücken, um die im Display angezeigte Nummer anzurufen. Foxtaste unter "Löschen" drücken, löscht den Eintrag aus der Anrufliste.

## Mikrofon ausschalten

Während eines Gesprächs möchten Sie mit einer anderen Person in Ihrem Büro ein paar Worte wechseln. Dazu können Sie das Mikrofon Ihres Handgeräts ausschalten.

Mikro



Foxtaste unter "Mikrofon" drücken. Das Mikrofon ist ausgeschaltet (Im Display erscheint das Symbol "⌘").

Mikro



Foxtaste unter "Mikrofon" nochmals drücken, um das Mikrofon wieder einzuschalten.

## Diskretruf einschalten

An einer Sitzung kann ein Anruf auf das Handgerät stören. Das Einschalten des Diskretrufs bewirkt, dass ein Anruf nur mit einem einzigen Rufton akustisch signalisiert wird. Sie können den Anrufer aufgrund der Display-Anzeige identifizieren und entscheiden ob Sie den Anruf beantworten wollen. Wenn nicht, wird er in die Anrufliste eingetragen. Das i-Symbol im Display wird Sie später daran erinnern. Der Diskretruf bleibt solange eingeschaltet, bis er bewusst wieder ausgeschaltet wird. Auch daran erinnert Sie das i-Symbol im Display.



Diskret



M-Taste so oft drücken bis "Diskretruf" erscheint. Foxtaste unter "Diskretruf" drücken.

## Hinweis

Der Diskretruf kann auch während eines Anrufs eingeschaltet werden. Bei jedem Anruf erscheint auf dem Display der Menüpunkt "Diskretruf". Der Rufton (nur der Ton, nicht der eigentliche Anruf) wird ausgeschaltet, sobald der Diskretruf eingeschaltet wird.

# So benutzen Sie die Komfortfunktionen

## Diskretruf ausschalten



Zurückst.



i-Taste so oft drücken bis im Display "Diskretruf" und "Zurückstellen" erscheint. Foxtaste unter "Zurückstellen" drücken; der Diskretruf ist ausgeschaltet.

## Verbindung parken

Während eines Gesprächs kann ein dritter Teilnehmer bei Ihnen "Anklopfen". Wenn sie diesen Anruf beantworten, geht die Verbindung zu Ihrem ersten Gesprächspartner in "Haltung". Bevor Sie die zweite Verbindung weitervermitteln können, müssen Sie die gehaltene Verbindung parken.

2. \_Gespr



Parken



Foxtaste unter "2. \_Gespräch" drücken, um die Verbindung zum gehaltenen Gesprächspartner wieder herzustellen. M-Taste so oft drücken bis "Parken" angezeigt wird. Foxtaste unter "Parken" drücken, um die aktuelle Verbindung zu parken.

2. \_Gespr



Foxtaste unter "2. \_Gespräch" drücken, um zum zweiten Gesprächspartner zu wechseln. Nun können Sie ihn weitervermitteln.

Zurückn.



Foxtaste unter "Zurücknehmen" drücken, um die Verbindung zum wartenden Gesprächspartner wieder herzustellen.

## Hinweis

Im Unterschied zu einer gehaltenen Verbindung, während welcher beide verfügbaren Gesprächskanäle belegt sind, wird für das Parken kein Gesprächskanal benötigt. Dies hat den Vorteil, dass Sie den anklopfenden Teilnehmer (falls nötig) weiter verbinden können. Erscheint [P], so ist bereits eine Verbindung geparkt.

## Makeln

Nach dem Aufbau einer Rückfrageverbindung können Sie zu Ihrem ursprünglichen Gesprächspartner wechseln, ohne die Rückfrageverbindung zu beenden, d.h. Sie können zwischen Ihren beiden Gesprächspartnern beliebig oft wechseln (makeln).

2. \_Gespr



Foxtaste unter "2. \_Gespräch" drücken, um zum 1. Gesprächspartner zu wechseln.

2. \_Gespr



Foxtaste unter "2. \_Gespräch" drücken, um die Verbindung zum Rückfragepartner wieder durchzuschalten usw. (so oft wie gewünscht oder notwendig).

# So benutzen Sie die Komfortfunktionen

## Gespräch übergeben

Nach dem Aufbau einer Rückfrageverbindung können Sie Ihre beiden Gesprächspartner direkt miteinander verbinden.



Gesprächstaste drücken.  
Ihr Handgerät nimmt automatisch den Ruhezustand ein.

## Konferenz

Sie haben eine Rückfrageverbindung aufgebaut und wollen nun zusammen mit Ihrem ursprünglichen Gesprächspartner ein Konferenzgespräch (zu dritt) führen.



M-Taste und danach Foxtaste unter "Konferenz" drücken.

## Hinweis

Keine Angst! Beim Aufbau einer Konferenz werden keine Gespräche unterbrochen; Verbindungen werden allein mit der C-Taste oder der Gesprächstaste unterbrochen!

## Anrufumleitung

Sie können Anrufe auf einen anderen Apparat bzw. auf denjenigen der Telefonistin umleiten, oder eine Nachricht hinterlassen.



M-Taste so oft drücken bis "Umleiten" erscheint und Foxtaste unter "Umleiten" drücken.  
Mit Foxtaste unter "\*" die Umleitungsart wählen (z.B. Umleiten wenn besetzt oder Rufweiter-schaltung).



Umleitziel wählen und ggf. neue Rufnummer eingeben.  
Mit "Ok" bestätigen..

## Hinweis

Soll die Umleitung nur erfolgen wenn Sie bereits in einer Verbindung sind, wählen Sie "Uml. besetzt".

## Twin Mode (anwesend/abwesend)

Haben Sie zu Ihrem Handgerät gleichzeitig ein drahtgebundenes Endgerät, wird mit dem Twin Mode Ihre Erreichbarkeit auf einfachste Weise sichergestellt. Bei programmiertem Twin Mode (siehe "So programmieren Sie Ihren Apparat") wird automatisch die Anrufumleitung aktiviert, sobald Sie das Handgerät aus der LademuLde nehmen.

# So benutzen Sie die Komfortfunktionen

## Nachricht hinterlassen

Sie verlassen Ihren Arbeitsplatz (ohne Handgerät) und möchten Anrufern eine Nachricht hinterlassen.

- |   |  |   |  |
|---|--|---|--|
|  |  Uml. |  | M-Taste so oft drücken bis "Umleiten" erscheint<br>Foxtaste unter "Umleiten" und danach unter<br>"☒" drücken bis im Display "Uml. zu Nachr."<br>(Umleiten zu Nachricht) erscheint. |
|   |  Ok   |  | Foxtaste unter "Ok" drücken und danach<br>unter "☒" so oft drücken bis eine passende<br>Nachricht angezeigt wird (i-Symbol in<br>Display) .  |
|   |  |  | i-Taste ein- oder mehrmals drücken, um die<br>ganze Nachricht anzuzeigen.  |
|  |  End  |  | Mit C-Taste und Tastenblock Meldung editieren<br>(falls nötig, siehe "Wahl mit Namen").<br>Foxtaste unter "Ok" drücken.  |
|   |       |   |  |



## Hinweis

Sie können die Standardnachricht mit der C-Taste auch ganz löschen und eine eigene Nachricht schreiben.

## Verlangter Rückruf (Rückruf ausführen)





Ein Teilnehmer hat eine wichtige Mitteilung für Sie. Trotz Ihres Handgeräts konnte er Sie nicht erreichen. Von seinem Systemendgerät aus fordert er einen Rückruf von Ihnen an.

Im Display Ihres Handgeräts wird "Bitte Rückr." und "Anruf" "Lösche" angezeigt.

- |   |       |   |  |
|---|-------|---|--|
|  | Anruf |  | Foxtaste unter "Anrufen" drücken, um dem<br>Anrufer zurückzurufen oder unter "Löschen",<br>falls Sie den Rückruf nicht mehr für sinnvoll oder<br>notwendig halten. |
|---|-------|---|--|

## Personensuche

Einen Teilnehmer nach einem erfolglosen Anrufversuch (oder direkt) via Personensuchanlage suchen.

- |   |  |   |  |
|---|--|---|--|
|  |  Such |  | M-Taste so oft drücken bis "Suchen" erscheint.<br>Foxtaste an dieser Stelle drücken, die<br>Anschlussnummer des gesuchten Teilnehmers<br>eingeben und mit "Ok" bestätigen. |
|   |  Ok   |   |  |

# So benutzen Sie die Komfortfunktionen

## Rückruf verlangen

Sie bitten einen besetzten oder nicht antwortenden Teilnehmer, Sie zurückzurufen.



Rückr. Foxtaste unter "Rückruf" drücken. Sie hören den Bestätigungston. Im Display erscheint "Anruf erwartet von Nummer nnn" und "Zurückstellen"



Zurückst. Mit der Foxtaste unter "Zurückstellen" kann die Funktion "Rückruf verlangen" deaktiviert werden.

## Hinweis

Gleichzeitig kann nur ein Rückruf aktiviert werden.

## Meldung senden

In der PBX sind Standardmeldungen gespeichert. Sie können eine davon auswählen, eventuell ergänzen oder ändern und an den betreffenden Teilnehmer oder eine Gruppe senden.



Menütaste so oft drücken bis "Meldung" erscheint. Foxtaste unter "Meldung" drücken. Foxtaste unter "i" so oft drücken bis eine passende Meldung angezeigt wird (i-Symbol in Display).



i-Taste ein- oder mehrmals drücken, um den Rest der Meldung anzuzeigen.



Mit C-Taste und Tastenblock Meldung editieren (falls nötig, siehe "Wahl mit Namen"). Foxtaste unter "Ok" drücken.



Nummer des Teilnehmers/der Gruppe wählen, für den die Meldung bestimmt ist. Foxtaste unter "Ok" drücken, um die Meldung zu senden.

## Hinweise

- Die Prozedur kann auch mit "Wahlvorbereitung" eingeleitet werden, d.h. zuerst die Nummer eingeben und anschließend die Meldung wählen.
- Sie können die Standardmeldung mit der C-Taste natürlich auch ganz löschen und eine eigene Meldung schreiben.

# So benutzen Sie die Komfortfunktionen

## Meldung lesen

Haben Sie eine Meldung erhalten, werden im Display "Meldung", die Nummer des Absenders sowie die Menüpunkte "Lesen" und "Löschen" angezeigt.

Lesen



Foxtaste unter "Lesen" drücken. Das "+" Zeichen besagt, dass mehr Information vorhanden ist.



i-Taste drücken, um die nächste Zeile zu sehen.

Am Ende der Meldung wechselt die Display-Anzeige wieder zu den anfänglichen Menüpunkten "Lesen" und "Löschen".

Lösche



Foxtaste unter "Löschen" drücken.

## Hinweis

Um weitere (evtl. vorhandene) Meldungen angezeigt zu erhalten, muss die gelesene Meldung gelöscht werden.

## Durchsage

Von Ihrem Handgerät aus können Sie Durchsagen zu einem oder mehreren internen Teilnehmern machen, vorausgesetzt, dass deren Systemendgeräte über eine Lautsprechereinrichtung verfügen.



Durchs



M-Taste so oft drücken bis "Durchsage" erscheint. Foxtaste an dieser Stelle drücken.

Gruppe



Gewünschte Teilnehmernummer eingeben. (Oder Foxtaste unter "Gruppe" drücken und Gruppen-Nummer eingeben; für Durchsage zu vordefinierter Teilnehmergruppe).

Ok



Foxtaste unter "Ok" drücken und Durchsage machen.

# So benutzen Sie die Komfortfunktionen

## Transparentmodus einschalten (Frequenzwahl DTMF)

Während einer Verbindung kann mit Frequenzwahl eine Funktion, z.B. die Fernabfrage eines Anrufbeantworters aktiviert werden.



"Long Click" der \*-Taste bis "Transparent" erscheint. Zeichenfolge zur Aktivierung der gewünschten Funktion eingeben.

Nach erfolgreicher Ausführung:



C-Taste drücken, um den Transparentmodus wieder auszuschalten.

oder

Zurückst.



Foxtaste unter "Zurückstellen" drücken.

## Rückfrage einleiten/abschliessen

Während eines Gesprächs stellt Ihr Partner eine Frage, die Sie nicht beantworten können. Sie wollen einen anderen Mitarbeiter um Auskunft bitten, ohne die aktuelle Verbindung zu beenden.



Rückf.



Nummer des Teilnehmers eingeben, den Sie um Rat bitten wollen.

Foxtaste unter "Rückfrage" drücken; der Teilnehmer wird gerufen (die bisherige Verbindung wird gehalten).

Nach Erhalt der gewünschten Auskunft:



C-Taste drücken, um die Verbindung zum wartenden Gesprächspartner wieder durchzuschalten.

## Hinweis

Wird nach einer Rückfrage die Gesprächstaste gedrückt, so ertönt 10s lang ein Dauerruf. Während des Dauerrufs die Gesprächstaste drücken, um die Verbindung zum wartenden Gesprächspartner wieder herzustellen.

# So programmieren Sie Ihren Apparat

## Was Sie beim Programmieren beachten müssen

Die Programmierung ist Bestandteil des Bedienkonzeptes; bevor Sie mit dem Programmieren beginnen, lesen Sie bitte das Kapitel "Bedienkonzept" am Anfang dieser Bedienungsanleitung.

## Programmiermodus

Zum Anfang des Programmiermodus gelangt man auf 2 Arten:

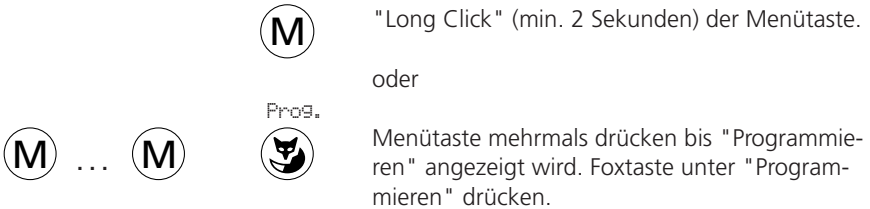

## Hinweis

"Long Clicks" sind von der Software und dem PBX-Typ abhängig.

## Menütaste

Mit der Menütaste bewegen Sie sich auf zwei Ebenen: zunächst in den Programmiermenüs (PRG 1-...; anwählen des gewünschten zu programmierenden Bereichs, z.B. "Tasten") und anschliessend auf der Ebene der Unterfunktionen (z.B. Belegen einer Nummerntaste). Beide Ebenen verlassen Sie jeweils durch Drücken der C/End-Taste oder der Gesprächstaste.

## Speichern

Ein von Ihnen eingegebener oder geänderter Inhalt unter einem Menüpunkt ist dann gespeichert, wenn Sie die Foxtaste unter "Ok" drücken. Drücken Sie eine andere Taste, wird die von Ihnen vorgenommene Programmierung nicht gespeichert.

# So programmieren Sie Ihren Apparat

## Menü Übersicht

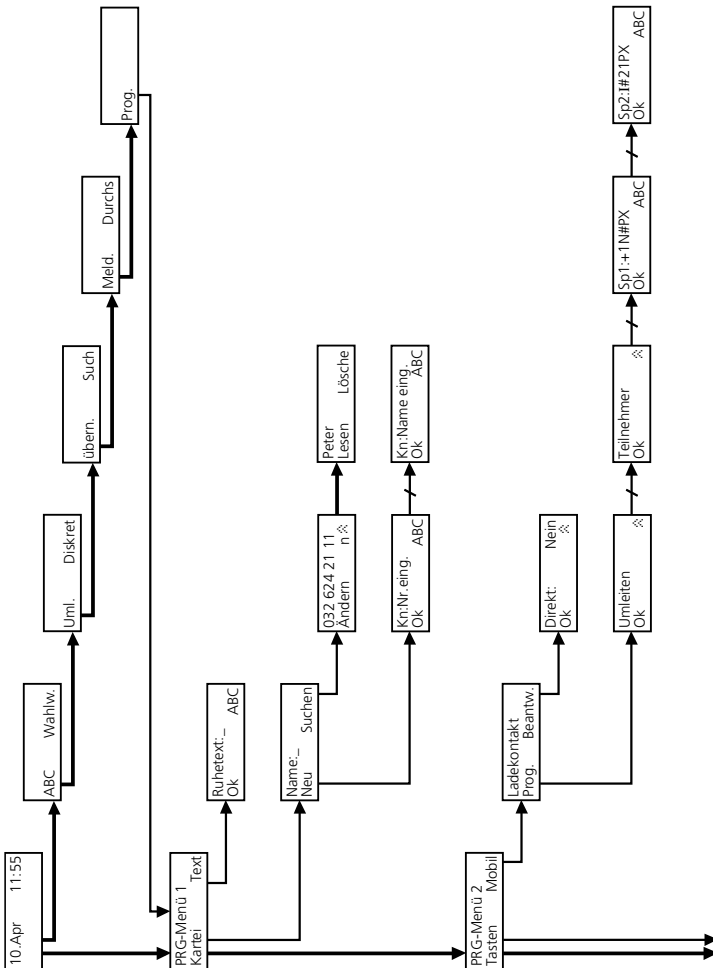





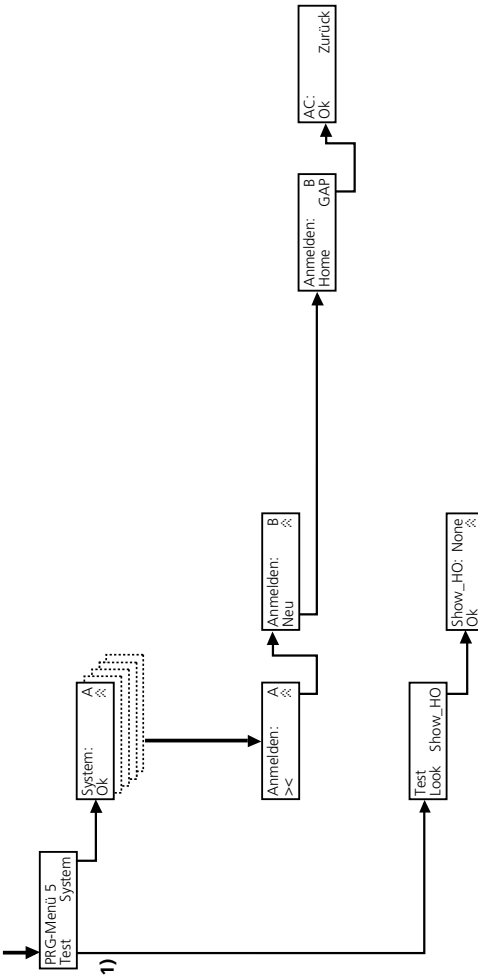

1)

↑ Menütaaste

↑ Foxtaste

↗ Foxtaste (Ok)

1) Der Menüpunkt "Test" ist dem Installateur vorbehalten

# So programmieren Sie Ihren Apparat

## Twin Mode (anwesend/abwesend)

Haben Sie zu Ihrem Handgerät gleichzeitig ein drahtgebundenes Endgerät, wird mit dem Twin Mode Ihre Erreichbarkeit auf einfachste Weise sichergestellt.





Der Ladekontakt erkennt 2 Zustände:

- Handgerät in LademuLde (anwesend)
- Handgerät nicht in LademuLde (abwesend)



Aufgrund dieser Zustände wird die automatische Anrufumleitung (AUL) zum Handgerät ausgeführt, sobald dieses aus der LademuLde genommen wird.

Nach dem Zurücklegen des Handgeräts in die LademuLde ist die Anrufumleitung automatisch wieder ausgeschaltet.

## Twin Mode aktivieren

		Mobil	Im Programmiermodus M-Taste so oft drücken bis "Mobil" erscheint. Foxtaste unter "Mobil" drücken.
Prog.			Foxtaste unter "Prog." drücken, danach mit Foxtaste unter "☼" bis "Twin" blättern und mit "Ok" bestätigen.
		Ok	Bei "TwinNr.:" die Anschlussnummer des drahtgebundenen Endgeräts eingeben, das auf das Handgerät umgeleitet werden soll. Twin Mode mit Foxtaste unter "Ok" aktivieren.

## Twin Mode deaktivieren

		Mobil	Im Programmiermodus M-Taste so oft drücken bis "Mobil" erscheint. Foxtaste unter "Mobil" drücken.
Prog.			Foxtaste unter "Prog." drücken, danach mit Foxtaste unter "☼" bis "Keine Funkt." blättern und mit der Foxtaste unter "Ok" den Twin Mode deaktivieren.

## Hinweise

- Wird am drahtgebundenen Endgerät bewusst eine AUL/RWS zur Sekretärin, zu Voice Mail oder zum eigenen GSM-Gerät etc. aktiviert, während sich das Handgerät in der LademuLde befindet, so hat diese eine höhere Priorität als der Twin Mode. Es erfolgt keine automatische Umleitung zum Handgerät, wenn dieses aus der LademuLde genommen wird. Der Twin Mode wird wieder aktiviert, sobald die am drahtgebundenen Endgerät aktivierte AUL/RWS zurückgestellt wird.
- Nebst dem Twin Mode können auch andere Funktionen eingestellt werden (siehe Programmieranleitung "Mobil")

# So programmieren Sie Ihren Apparat

## Privatkartei

Neben dem vorhandenen PBX-Teilnehmer-Verzeichnis und der Kurzwahlliste, können Sie sich eine private Kartei mit bis zu 30 (00 bis 29) Telefonnummern und Namen anlegen. Die Einträge können Sie durch das Sperren der Programmierfunktionen Ihres Handgerätes vor fremdem Zugriff schützen.



Im Programmiermodus M-Taste so oft drücken bis "Kartei" erscheint.

Kartei



Funktaste unter "Kartei" und anschliessend unter "Neu" oder "Suchen" drücken.

Neu



Ok



Bei "Neu" wird die nächste freie Karteikarte angezeigt. Nummer eingeben und mit "Ok" bestätigen, Namen eingeben und mit "Ok" speichern.

Suchen



⌘



Bei "Suchen" mit Foktaste unter "⌘" bis zum gesuchten Eintrag blättern.

Ändern



Ok



Foktaste unter "Ändern" drücken, die gespeicherten Einträge ändern und mit Foktaste unter "Ok" speichern.

## Hinweise

- Wenn eine Karteikarte bereits ausgefüllt ist, wird der aktuelle Eintrag angezeigt. Sie können diesen selbstverständlich editieren.
- Es ist ratsam zu jeder Nummer den zugehörigen Namen einzugeben; dies ermöglicht die bequeme Suche und die Wahl mit Namen aus einer Kartei.
- Wird bei einem Anruf die Nummer des Rufenden auf dem Display angezeigt (CLIP), so sucht das System in den Verzeichnissen und der Privatkartei nach dieser Nummer. Ist sie bereits mit einem Namen gespeichert, so wird auch der Name angezeigt.

# So programmieren Sie Ihren Apparat

## Makrosprache

Die Makrosprache ermöglicht verschiedene Funktionen nacheinander unter einer Taste abzulegen.

I	Belegen
X	Verbindung abbauen
P	Pause (1 Sekunde)
N	In Wahlvorbereitung eingegebene Nummer einsetzen
*	Steuertastenfunktion
Z	Transparentmodus ein-/ausschalten
R	Zuletzt gewählte Nummer einsetzen

Beispiele:

I201 Belegen und 201 anrufen

I\*21201X Belegen, Anrufumleitung auf 201 und Verbindung abbauen.

## Ruhetext programmieren

Anstelle von Datum und/oder Uhrzeit können Sie für den Ruhezustand Ihres Handgeräts einen persönlichen Text definieren.

Text



Im Programmiermodus Foxtaste unter "Text" drücken und Text eingeben (maximal 12 Zeichen).

Ok



Foxtaste unter "Ok" drücken, um die Eingabe zu speichern.

End



Ruhetext editieren (falls nötig).

Mit der Korrekturtaste (C/End) können die Zeichen links vom Cursor gelöscht werden.

Ok



Nach dem Editieren des Ruhetextes Foxtaste unter "Ok" drücken.

## Hinweis

Ein "Long Click" der C/End-Taste (min. 2 Sekunden) bewirkt einen Rücksprung zum vorhergehenden Menü.

# So programmieren Sie Ihren Apparat

## Tastatur sperren/entsperren

Sie können die Tastatur gegen unbeabsichtigtes Betätigen sperren. Anrufe werden signalisiert und können mit der Gesprächstaste entgegengenommen werden. Nach dem Gespräch kann innerhalb von 5s eine abgehende Verbindung aufgebaut werden. Nach 5s wird die Tastensperre (Variante 1) wieder aktiviert.



Im Programmiermodus M-Taste so oft drücken bis "Tasten" erscheint.

Tasten



Foxtaste unter "Tasten" drücken. Im Display erscheint "Tastensperre".

Ok



Tastensperre mit Foxtaste unter "Ok" aktivieren.

Die Display-Anzeige wechselt zu "Entsperren".

Entsperren



Foxtaste unter "Entsperren" drücken. Das Handgerät fordert mit "Sperrung aus?" eine Bestätigung, dass die Tastensperre deaktiviert werden soll.

Ja



Mit "Ja" erscheint das "Ruhe-Display"; das Handgerät ist wieder betriebsbereit.

## Hinweise

- Mit "Long Click 8" (min. 2 Sekunden) kann Variante 1 der Tastensperre ebenfalls eingeschaltet werden.
- Mit "Long Click 9" kann Variante 2 der Tastensperre eingeschaltet werden. Diese wird bei einem Anruf nicht automatisch aufgehoben, sondern muss manuell erfolgen (siehe oben), um den Anruf mit der Gesprächstaste entgegennehmen zu können.

# So programmieren Sie Ihren Apparat

## Hotkey-Programmierung

Der Hotkey ist eine frei programmierbare Taste, unter der bis zu 6 Nummern/Namen oder Funktionen abgelegt werden können. Mit Hilfe der Makrosprache können Sie ganze Bedienabläufe speichern.

### Nummer/Namen unter dem Hotkey ablegen

- |  |  |  |
|--|--|--|
|   |  Tasten | Im Programmiermodus M-Taste so oft drücken bis "Tasten" erscheint.<br>Foftaste unter "Tasten" drücken.   |
|   |  Ok     | Foftaste unter "☼" so oft drücken bis "Hotkey" erscheint und Foftaste an dieser Stelle drücken. Das Menü "Hotkey Programmierung" mit den Menüpunkten "Hk1" und "Hk2" erscheint im Display. |
|   |  Ok     | Durch ein-/zweimaliges Drücken der M-Taste die Speicher "Hk3" und "Hk4" bzw. "Hk5" und "Hk6" aufrufen.<br>Den gewünschten Speicher (Hk1...Hk6) mit Foftaste wählen.                        |
|  |  Ok     | Im Menü "Nn : Nummer" nochmals mit "Ok" bestätigen.  |
|  |  Ok    | Nummer eingeben und mit "Ok" bestätigen, Namen eingeben und Foftaste unter "Ok" drücken, um den Eintrag zu speichern.  |

### Hinweis

Ein "Long Click" der Hotkey Taste bewirkt den direkten Sprung zur Hotkey-Programmierung.

# So programmieren Sie Ihren Apparat

## Funktion unter dem Hotkey ablegen

Gleiches Vorgehen wie unter Nummern/Namen, bis zur Wahl des Speichers Hk1...Hk6, danach:



Foxtaste unter "\*" drücken, um das Menü "Fn : Funktion" aufzurufen und mit "Ok" zu bestätigen.



Foxtaste unter "\*" so oft drücken bis die gewünschte Funktion angezeigt wird und mit "Ok" bestätigen.



Es wird Speicherinhalt 1 (Sp1) für diese Funktion angezeigt (Funktion aktivieren). Foxtaste unter "Ok" drücken, um die Funktion zu speichern.



Falls gewünscht Namen eingeben und mit "Ok" bestätigen. Es wird Speicherinhalt 2 (Sp2) angezeigt (Funktion deaktivieren).



Mit "Ok" wird die Funktion gespeichert.

## Hinweise







- In die beiden Speicherplätze werden autom. die entsprechenden Funktionscodes eingetragen. Bei Bedarf können diese ergänzt/geändert werden.
- Wird während des Speichervorgangs kein Name eingegeben, wird ein kurzer Default-Name eingesetzt z.B. "Anr.sch." für "Anrufschutz".
- Ist eine der programmierten Funktionen aktiv, wird dies in der Symbolzeile mit dem Symbol "■" und bei der zugehörigen Funktion mit "☒" angezeigt.
- Ein "Long click" der Hotkey-Taste bewirkt den direkten Sprung zur Hotkey-Programmierung.

# So programmieren Sie Ihren Apparat

## Foxtasten Programmierung

Sie können beide Foxtasten auch als frei programmierbare Tasten verwenden. Im Ruhezustand zeigt Ihr Display dann sehr häufig benutzte Nummern oder Funktionen an, die Sie mit einem einzigen Tastendruck (auf das zugehörige Füchtlein) sehr bequem ausführen können. Ist unter der Foxtaste eine Funktion abgelegt, so wird deren Aktiv-Zustand mit dem "¶" Symbol angezeigt.

### Nummern/Namen oder Funktionen unter Foxtaste ablegen







	Tasten 	Im Programmiermodus M-Taste so oft drücken bis "Tasten" erscheint. Foxtaste unter "Tasten" drücken.
		Foxtaste unter "✱" so oft drücken bis "Foxtaste" erscheint.
	Ok 	Foxtaste unter "Ok" drücken und anschliessend die gewünschte Taste ("Fox 1" oder "Fox 2") wählen.
Fox 1 	Fox 2 	Weiter wie unter "Hotkey-Programmierung".

### Hinweise

- Ein "Long click" der Foxtaste bewirkt den direkten Sprung zur Foxtasten-Programmierung.
- Wenn beide Foxtasten mit einer Nummer oder Funktion **und** einem Namen belegt werden, verschwindet die Qualitätsanzeige.
- Die Qualitätsanzeige bleibt erhalten, wenn bei Foxtaste 1 oder 2 statt eines Namens mit der # -Taste ein Leerzeichen eingegeben wird.

### Tasten-Quittungston

Das Handgerät kann, wenn gewünscht, jeden Tastendruck mit einem kurzen Quittungston bestätigen.

	Tasten 	Im Programmiermodus M-Taste so oft drücken bis "Tasten" erscheint. Foxtaste unter "Tasten" drücken.
	Ok 	Foxtaste unter "✱" drücken bis "Quittungston" erscheint und mit "Ok" bestätigen.
	Ok 	Mit Foxtaste unter "✱" "Ton: Ja" oder "Ton: Nein" wählen. Foxtaste unter "Ok" drücken, um die Einstellung zu speichern.

### Hinweis

Das Zurücklegen des Handgerätes in die Lademulde wird immer mit einem kurzen Ton quittiert.

# So programmieren Sie Ihren Apparat

## Direkt beantworten (ohne Gesprächstaste)

Ist das Handgerät auf "Direkt" beantworten eingestellt, wird ein Anruf durch das Herausnehmen des Handgeräts aus der LademuLde direkt entgegen genommen, ohne die Gesprächstaste zu drücken.

Das Zurücklegen des Handgeräts in die LademuLde bewirkt immer das Abbauen einer Verbindung, falls diese nicht vorher mit der Gesprächstaste beendet wurde.



Im Programmiermodus M-Taste so oft drücken bis "Mobil" erscheint.

Foxtaste unter "Mobil" und anschliessend unter "Beantworten" drücken.



Mit Foxtaste unter "☼" auf "Direkt: Ja" um-

schalten und diese Einstellung mit Foxtaste unter "Ok" bestätigen.

## Handgerät aus-/einschalten

### Ausschalten



Im Programmiermodus M-Taste so oft drücken bis "Gerät" erscheint.



Foxtaste unter "Gerät" drücken; es erscheint "Ausschalten".



Foxtaste unter "Ok" drücken, um das Gerät auszuschalten.

Die Verbindung zur Funkeinheit wird unterbrochen (keine Displayanzeige).

### Hinweise

- Mit "Long Click 0" (min. 2 Sekunden) wird das Handgerät ebenfalls ausgeschaltet.
- Ausserhalb des Funkbereichs versucht das Handgerät immer wieder eine Verbindung zu einer Funkeinheit herzustellen. Um die Batterie zu schonen, sollte das Gerät ausgeschaltet werden, wenn der Bereich für längere Zeit verlassen wird.

### Einschalten



Gesprächstaste drücken und Gerät mit Foxtaste unter "Ja" einschalten.

# So programmieren Sie Ihren Apparat

## Handgerät sperren/entsperren

Sie können Ihr Handgerät gegen unbefugten Gebrauch sperren. Ihr Systemmanager kann Ihnen Auskunft darüber geben, ob und wenn ja welche Verbindungen (z.B. Notrufnummern) trotz der Sperre gewählt und aufgebaut werden können.

Im gesperrten Zustand können Sie jederzeit Anrufe mit der Gesprächstaste sofort entgegennehmen. Vor abgehenden Gesprächen ist das Handgerät zu entsperren.

Es ist empfehlenswert mit "Prog.: gesp." die Programmierfunktionen Ihres Handgeräts zu sperren. Damit schützen Sie z.B. die Einträge in Ihrer Privatkartei.



Im Programmiermodus M-Taste so oft drücken bis "Gerät" erscheint und anschliessend die Foxtaste unter "Gerät" drücken; es erscheint "Ausschalten".

Mit der Foxtaste unter "❄" "Sperren" wählen, "Ok" drücken und Code (Passwort) eingeben.

Foxtaste unter "Ok" drücken, um eine Passwort-Kontrolle zu veranlassen.

Mit der Foxtaste unter "❄" "frei", "Prog. gesp." (Programmieren gesperrt) oder "gesperrt" wählen (mit "frei" wird eine Sperre deaktiviert), und mit "Ok" bestätigen.

## Code/Passwort ändern

Nach dem erstmaligen Einschalten des Handgeräts hat der Code/das Passwort den Wert "0000". Es wird empfohlen sofort ein persönliches Passwort aus 2 bis zu 10 Ziffern zu definieren, um die persönliche Einstellung Ihres Handgeräts und die darin gespeicherten Daten vor unbefugter Benutzung (ändern, löschen) zu schützen.



Im Programmiermodus M-Taste so oft drücken bis "Code" erscheint. Foxtaste unter "Code" drücken und aktuellen Code eingeben.

Foxtaste unter "Ok" drücken und neuen Code eingeben.

Foxtaste unter "Ok" drücken, es erscheint "Bestät.:" (Bestätigen).

Neuen Code nochmals eingeben und mit Foxtaste unter "Ok" bestätigen.

# So programmieren Sie Ihren Apparat

## Ruf und Diskretruf einstellen

Ihr Handgerät kann einen Anruf mit verschiedenen Lautstärken, Rufmelodien und Geschwindigkeiten (Tempo) signalisieren. Sie können die Ihnen zusagende Version wählen, und erkennen dann leichter, ob ein Anruf für Sie bestimmt ist oder eventuell vom Handgerät Ihres Nachbarn stammt.

Bei "Diskretruf" wird ein Anruf nur mit einem einzigen Ruftönen akustisch signalisiert.

- |     |   |   |
|-----|---|---|
|     |  | Im Programmiermodus M-Taste so oft drücken bis "Ruf" erscheint.   |
| Ruf |  | Foxtaste unter "Ruf" drücken und mit Foxtaste unter "❖" "Normalruf" oder "Diskretruf" wählen.   |
|     |  | Foxtaste unter "Ok" drücken, um das aktuelle Rufsignal einzuschalten.   |
|     |  | Foxtaste unter "❖" so oft drücken bis die gewünschte Lautstärke erreicht ist.   |
| Ok  |  | Foxtaste unter "Ok" drücken, um die Einstellung zu speichern und im nächsten Menü mit Foxtaste unter "❖" eine Melodie wählen.   |
|     |  |   |
| Ok  |  | Nach dem Speichern der Melodie mit "Ok", im Menü "Ruftempo" Foxtaste unter "❖" drücken, um die gewünschte Rufgeschwindigkeit einzustellen und mit Foxtaste unter "Ok" bestätigen. |
|     |  |   |
|     |  |   |

## Hinweis

Mit der M-Taste können Sie zwischen den Menüpunkten "Ruflautstärke", "Rufmelodie" und "Ruftempo" wechseln, ohne eventuell ausgeführte Änderungen zu speichern.

# Störungen

## **Verlassen des Funkbereichs**

Kurz vor dem Verlassen des Funkbereichs erfolgt ein Warnton. Nach dem Verlassen erscheint die Meldung "Kein System" und das Antennensymbol (📶) verschwindet. Wird der Funkbereich während eines Gesprächs verlassen, wird dieses zwar unterbrochen, jedoch die Verbindung nicht sofort abgebaut. Das System versucht dann ca. 20 s lang eine neue Funkverbindung mit derselben oder einer anderen Funkeinheit herzustellen. Erst danach wird die Verbindung in der PBX abgebaut.

Ausserhalb des Funkbereichs stehen Ihnen mit der M-Taste folgende Programmierfunktionen zur Verfügung:

"Prog.", "Tasten", "Mobil", "Gerät", "Ruf", "\*Sprache", "Test" und "System"

## **Anzeige im Display, kein Wählton**

Möglicherweise ist das Handgerät gesperrt (siehe "Handgerät sperren/entsperren").

## **Der Hotkey und/oder die Foxtaste lassen sich nicht programmieren**

Möglicherweise ist die Programmierung gesperrt (siehe "Handgerät sperren/entsperren").

## **Entsperren des Handgeräts; Passwort vergessen**

Bitte Sie die Telefonistin Ihr Passwort von der Zentrale aus zu überschreiben.

## **Anzeige im Display**

### **"Bitte warten"**

Diese Meldung kann während der Anmeldeprozedur erfolgen. Sie erscheint auch, wenn ein Gesprächspartner die Verbindung in den Haltezustand gebracht hat.

### **"Handset unbekannt"**

Die Anmeldung des Handgeräts am PBX-System ist misslungen. Bitte den Systemmanager fragen.

### **"Überlast"**

Keine freien Ressourcen, bitte warten und nochmals versuchen.

### **"System Busy"**

Über die aktuelle Funkeinheit kann momentan keine Verbindung aufgebaut werden. Das Handgerät versucht eine bessere Funkverbindung mit derselben oder einer anderen Funkeinheit herzustellen. Die Meldung erscheint nur im Ruhezustand.

### **"Kein System"**

Der Funkbereich wurde verlassen; die Funkverbindung ist unterbrochen.

### **"Anmelden"**

Die Anmeldeprozedur am PBX-System ist in Gang.

## **"Defekt" / permanenter progressiver Ruf**

Jedesmal wenn das Handgerät in die Lademulde gelegt wird, werden seine Parameter überprüft. Wird ein Parameter-Fehler festgestellt, erfolgt ein akustisches Fehlersignal und auf dem Display wird "Defekt" angezeigt. Das Handgerät muss zur Reparatur/Austausch an den Lieferanten zurück.

## **Hinweis**

Bei anderen Meldungen fragen Sie bitte Ihren Systemmanager.

# Funktionscodes

## Welche Ziffern muss man wählen?

Normalwahl	Tastenfolge
<b>Amtsengang</b>	
Geschäft .....	0 .....
Privat .....	10 .....
mit Kostenstelle-Nr .....	13 KST-Nr. ....
<b>Kurzwahlnummern PBX</b> .....	7000...7999 <sup>1)</sup> .....
<b>Leitwegnummern</b> .....	170... 199 <sup>1)</sup> .....
<b>Notrufnummer</b> .....	12 .....
<b>Sammelanschlussnummern</b> .....	860... 888 <sup>1)</sup> .....
<b>Telefonistin</b> .....	11 .....
<b>Türsprechstellen</b> .....	851... 852 <sup>1)</sup> .....
<b>Nachwahl</b>	
<b>Anklopfen</b> .....	6 oder *43
abweisen .....	0
beantworten, Verbindung halten .....	2
beantworten Verbindung nicht halten .....	1
beantworten mit Konferenz .....	3
<b>Aufschalten</b> .....	7 oder *44
abweisen .....	0
beantworten, Verbindung halten .....	2
beantworten, Verbindung nicht halten .....	1
<b>Bitte Rückruf Nr. / MESSAGE</b>	
aktivieren .....	*38
<b>Coderuf aktivieren</b> .....	8 oder *81
<b>Konferenz</b>	
(aus Verbindung) aufbauen .....	3
Teilnehmer (intern), ausschliessen .....	*31
<b>Makeln</b> (hin- und herschalten zwischen zwei Verbindungen) .....	2
<b>Personensuchanlage aktivieren</b> .....	8 oder *81
<b>Rückkehr zur Erstverbindung</b> .....	1
<b>Rückruf</b>	
bei besetztem Teilnehmer aktivieren .....	9 oder *37
bei freiem Teilnehmer aktivieren .....	9 oder *37

<sup>1)</sup> Definition und Bereich der Nummern sind von der Software und dem PBX-Typ abhängig.

# Funktionscodes

## Umbuchen des laufenden

**Gespräch auf Kostenstelle-Nr.** ..... \*78 KST-Nr.

**Verbindung parken** ..... \*76

## Vorwahl

---

**Alle aktivierten Dienste deaktivieren** <sup>2)</sup> ..... \*00  
(Ausser Sammelanschluss)

### **Amtsausgang**

mit Gebührenrückruf aktivieren ..... \*32 TN-Nr.

### **Anklopfen** <sup>2)</sup>

sich schützen vor ..... \*04

auf sich erlauben ..... #04

**Anruf übernehmen** ..... \*86 TN-Nr.

### **Anrufumleitung AUL**

sich schützen vor AUL <sup>2)</sup> ..... \*02

AUL auf sich erlauben <sup>2)</sup> ..... #02

unbedingte AUL aktivieren <sup>2)</sup> ..... \*21 Ziel-Nr.

unbedingte AUL löschen <sup>2)</sup> ..... #21

unbedingte AUL auf zuletzt progr. Nummer aktivieren .... \*21#

unbedingte AUL auf zuletzt progr. Nummer löschen ..... #21

AUL auf vorprogrammierte Nummer aktivieren <sup>2)</sup> ..... \*22

AUL auf vorprogrammierte Nummer löschen <sup>2)</sup> ..... #22

AUL wenn besetzt aktivieren <sup>2)</sup> ..... \*67 Ziel-Nr.

AUL wenn besetzt löschen <sup>2)</sup> ..... #67

AUL wenn besetzt auf zuletzt progr. Nummer aktivieren . \*67#

AUL wenn besetzt auf zuletzt progr. Nummer löschen .... #67

AUL auf Standardmeldung aktivieren <sup>2)</sup> ..... \*24 Text-Nr.#

AUL auf Standardmeldung löschen <sup>2)</sup> ..... #24

AUL auf Personensuchanlage PSA oder

auf Zentralwecker mit Coderuf aktivieren <sup>2)</sup> ..... \*28

AUL auf Personensuchanlage PSA oder

auf Zentralwecker mit Coderuf löschen <sup>2)</sup> ..... #28

### **Aufschalten** <sup>2)</sup>

sich schützen vor ..... \*04

auf sich erlauben ..... #04

### **Coderuf**

aktivieren ..... \*81 TN-Nr.

beantworten ..... \*82

### **Courtesy (Ansgabe vor Melden)**

einschalten Gruppe 1 ..... \*931

ausschalten Gruppe 1 ..... #931

einschalten Gruppe 2 ..... \*932 <sup>1)</sup>

ausschalten Gruppe 2 ..... #932 <sup>1)</sup>

1) Definition und Bereich der Nummern sind von der Software und dem PBX-Typ abhängig.

2) Fernbedienung möglich

# Funktionscodes

## Durchsage

an einen Teilnehmer .....	*7998 TN-Nr.
an eine Gruppe .....	*79 GR-Nr.
an Gruppe übernehmen .....	*89

## Fernbedienung

<b>einleiten</b> (ab fremdem Apparat) .....	*06 TN-Nr. *21 Ziel-Nr.
Fernbedienung einleiten / fernbedienbare Teilnehmernummer eingeben / gewünschte *-Prozedur eingeben (z.B. *21 Ziel-Nr.)	

<b>ausschalten</b> (ab fremdem Apparat) .....	*06 TN-Nr. #21
Fernbedienung einleiten / fernbedienbare Teilnehmernummer eingeben / gewünschte #-Prozedur eingeben (z.B. #21)	

<b>ausschalten</b> (ab eigenem Apparat) .....	#21
#-Prozedur eingeben (z.B. #21)	

## Follow me

aktivieren .....	*23 TN-Nr.
löschen .....	#23

## Konferenz aufbauen

variable .....	*71 TN-Nr. 1* ... TN-Nr.5# <sup>1)</sup>
vorbestimmte .....	*70 Konf.-Nr.

## Meldungen (Standardmeldungen mit/ohne Parameter)<sup>2)</sup>

an Teilnehmer senden .....	*3598 TN-Nr. Text-Nr.#
an Gruppe senden .....	*35 GR-Nr. Text-Nr.#
an alle senden .....	*3599 Text-Nr.#

## Bitte Rückruf Nr. / MESSAGE<sup>2)</sup>

aktivieren .....	*38 TN-Nr.
löschen, Ziel-Apparat .....	#38 TN-Nr.

## Personensuchanlage

suchen .....	*81 TN-Nr.
mit einem Suchweg beantworten .....	*82
mit mehreren Suchwegen beantw. ....	*82 TN-Nr.

## Relais

einschalten .....	*755...*757 <sup>1)</sup>
ausschalten .....	#755...#757 <sup>1)</sup>

## Ruf auf Zentralwecker beantworten .....

\*83

1) Definition und Bereich der Nummern sind von der Software und dem PBX-Typ abhängig.

2) Fernbedienung möglich

# Funktionscodes

<b>Rückruf löschen</b> .....	#37
<b>Rufweiterleitung RWS</b> (Anrufumleitung wenn keine Antwort)	
sich schützen vor RWS <sup>2)</sup> .....	*02
RWS auf sich erlauben <sup>2)</sup> .....	#02
RWS aktivieren <sup>2)</sup> .....	*61 Ziel-Nr.
RWS löschen <sup>2)</sup> .....	#61
RWS auf zuletzt progr. Nummer aktivieren .....	*61#
RWS auf zuletzt progr. Nummer löschen .....	#61
RWS auf vorprogrammierte Nummer aktivieren <sup>2)</sup> .....	*62
RWS auf vorprogrammierte Nummer löschen <sup>2)</sup> .....	#62
RWS auf Personensuchanlage oder auf Zentralwecker mit Coderuf aktivieren <sup>2)</sup> .....	*68
RWS auf Personensuchanlage oder auf Zentralwecker mit Coderuf löschen <sup>2)</sup> .....	#68
<b>Ruhe vor dem Telefon</b> (Anrufschutz) <sup>2)</sup>	
aktivieren .....	*26
löschen .....	#26
<b>Sammelanschluss</b> <sup>2)</sup>	
sich einschalten .....	*48
sich ausschalten .....	#48
<b>Tag-, Nacht-, Wochenend-Schaltung</b> (Umschaltgr. 1)	
Tag (Position 1) .....	*8511
Nacht (Position 2) .....	*8512
Wochenende (Position 3) .....	*8513
<b>Terminruf</b> (Weckauftrag) <sup>2)</sup>	
Dauerauftrag aktivieren .....	*56 hh mm
Dauerauftrag löschen .....	#56
Einzelauftrag aktivieren .....	*55 hh mm
Einzelauftrag löschen .....	#55
<b>Türe öffnen</b> .....	*751...*752 <sup>1)</sup>
<b>Umschaltgruppe</b> (ankommend)	
Umschaltgruppe x, Pos. 1 .....	*85x1 <sup>1)</sup>
Umschaltgruppe x, Pos. 2 .....	*85x2 <sup>1)</sup>
Umschaltgruppe x, Pos. 3 .....	*85x3 <sup>1)</sup>
Hinweis: x ist eine Ziffer von 2...9	
<b>Verbindung</b>	
parken .....	*76
geparkte abrufen .....	#76

1) Definition und Bereich der Nummern sind von der Software und dem PBX-Typ abhängig.

2) Fernbedienung möglich

# Index

## A

ABC 13  
 Akkus 5, 8  
 Anrufliste 14  
 Anrufumleitung 16  
 Ausschalten 33

## C

Code/Passwort 5, 34

## D

Direkt beantworten 33  
 Diskretruf 14, 15  
 Display-Sprache einstellen 9  
 Display-Symbole 1  
 DTMF 20  
 Durchsage 19

## E

Einschalten 33

## F

Foxtaste 32  
 Foxtasten Programmierung 32  
 Frequenzwahl DTMF 20

## G

Gespräch übergeben 16

## H

Handgerät aus-/einschalten 33  
 Handgerät sperren/entsperren 34  
 Hörerlautstärke 11  
 Hotkey-Programmierung 30, 31

## I

Installation 6, 7, 8

## K

Kartei 13, 27  
 Konferenz 16

## L

"Long Click" Funktionen  
 Ⓞ Akku-Typ und Ladezustand 8  
 Ⓢ Foxtasten Programmierung 32  
 ⊗ Frequenzwahl DTMF einschalten 20  
 Ⓞ Handgerät ausschalten 33  
 Ⓜ Hotkey-Programmierung 30, 31  
 Ⓜ IPEI und PARK anzeigen 10  
 Ⓞ PBX-System einstellen 10  
 Ⓢ Pfeilrichtung ändern in "☒" 3  
 Ⓜ Programmiermodus 3, 21

Ⓞ Rücksprung zum vorhergehenden Menü 28  
 Ⓞ SW-Versionsnummer 10  
 Ⓞ Tastensperre (Variante 1) 29  
 Ⓞ Tastensperre (Variante 2) 29  
 Ⓞ Verbindungsqualität 2

## M

Makeln 15  
 Makrosprache 28  
 Meldung lesen 19  
 Meldung senden 18  
 Mikrofon ausschalten 14

## N

Nachricht hinterlassen 17

## P

Parken 15  
 Passwort 5, 34  
 PBX-System anmelden 9  
 PBX-System einstellen 10  
 Personensuche 17  
 Privatkartei 27  
 Programmierung 21

## R

Rückfrage 20  
 Rückruf 17, 18  
 Ruf- und Diskretruf einstellen 35  
 Ruhetext 28

## S

Sicherheitshinweise 4, 5  
 Störungen 36  
 Suchen 17

## T

Tastatur sperren/entsperren 29  
 Tasten-Quittungston 32  
 Transparentmodus 20

## U

Übernehmen 11  
 Umleitung 16

## V

Verbindung parken 15  
 Verlassen des Funkbereichs 36

## W

Wahl mit Hotkey 12  
 Wahl mit Namen aus einer Kartei 13  
 Wählen 12  
 Wahlwiederholung 12

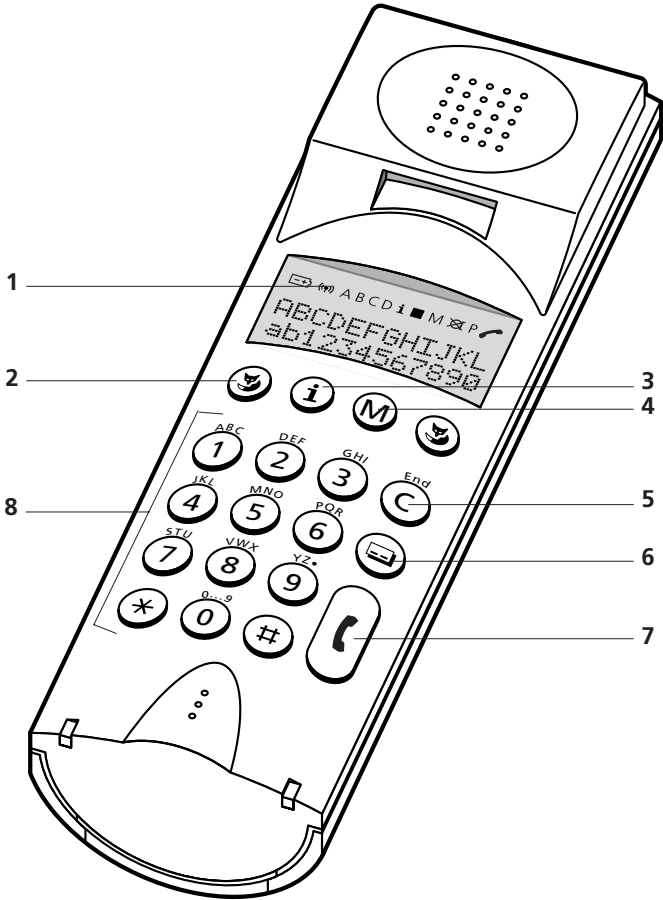

# Éléments de desserte et d'affichage

## 1 Écran d'affichage

L'écran d'affichage est formé d'une ligne de symboles, d'une ligne d'information et d'une ligne de menu de 12 caractères/symboles chacune.

## 2 Touches Fox

La ligne inférieure de l'écran affiche la fonction respective. Les deux touches fox sont librement programmables.

## 3 Touche i (d'information)

Permet de demander des informations supplémentaires (symbole i actif)

## 4 Touche M (menu)

Permet de rechercher le point désiré du menu; elle exerce une action cyclique, c'est-à-dire qu'après le dernier point d'un menu, on retrouve le premier (symbole M actif).

## 5 Touche C/End (effacement ou correction)

Touche d'effacement ou de correction (Clear) lors de l'introduction de chiffres. Retour au point de menu précédent ou au repos.

## 6 Hotkey (touche multifonction)

Touche librement programmable acceptant jusqu'à 6 numéros/noms ou fonctions.

## 7 Touche de conversation

Produit le même effet que de soulever/raccrocher le combiné. Réenclenchement de l'appareil portatif ayant été déclenché.

## 8 Clavier alphanumérique 0 à 9 (A à Z), \* et #

Entrée de chiffres et choix de fonctions de confort par procédures \*/#.

Entrée de noms et/ou de textes en mode alphanumérique (le passage des chiffres aux textes s'effectue automatiquement après le choix du menu correspondant.)

Exemple: 1 x touche 2 = D, 2x touche 2 = E, 3x touche 1 = C, 2x touche 7 = T

Avec la touche ⊕ vous pouvez aussi générer un espace.



# Éléments de desserte et d'affichage

## Symboles spéciaux



Etat de charge des accus

Pas d'affichage: Charge satisfaisante, appareil portable prêt à fonctionner.

Affichage clignotant: Charge basse (alerte)

Clignotant +

signal d'alerte: Charge très basse



Symbole d'antenne

Pas d'affichage: Hors de la portée d'émission/réception

Affichage permanent: Prêt pour communications entrantes et sortantes

A (B,C,D)

Affichage permanent: Appareil portable annoncé dans le système A (B,C ou D) et opérationnel.

Clignotant: Appareil portable inopérant.

ABCD

Clignotant: Appareil portable annoncé dans aucun système.

ABC

Affichage permanent: Numérotation alpha active



Informations supplémentaires (interrogation par touche i)



Une fonction programmée sur la Hotkey ou la touche Fox est à l'état actif.

M

Autres menus (commande par touche M)



Microphone hors service

P





Mode de programmation







Affichage permanent: Communication établie

Clignote: Signalisation optique d'un appel

Autres symboles sur ligne d'information ou de menu:

-  Défilement à travers une liste (avec numéro d'ordre de l'entrée)
-  Appel sur raccordement collectif (groupe d'abonnés)
-  Appel dévié
-  Fonction active

Qualité de la liaison radio (seulement dans l'affichage de repos)

-  Très bonne qualité de liaison
-  Bonne qualité de liaison
-  Téléphonie possible, perturbations probables
-  Téléphonie possible seulement sous condition, fortes restrictions
-  Téléphonie plus possible

### Remarque

La qualité de la liaison peut aussi être visualisée par une longue pression sur la touche 4. Le numéro de l'unité radio correspondante est affiché simultanément.

# Concept d'utilisation: la technique à menus

Vous pouvez programmer votre téléphone sans fil en fonction de vos besoins. Outre la mobilité, il vous offre toutes les fonctions téléphoniques que vous puissiez désirer, tout en étant simple et facile à utiliser (de façon intuitive), grâce à la touche Fox et à l'ingénieuse technique des menus. Le chapitre "Pour programmer l'appareil" et les instructions de programmation de votre terminal vous aideront à tirer le meilleur profit de toutes ses caractéristiques.

## Règles générales d'exploitation

Il existe deux types de menus:

- les menus d'exploitation les plus courants, correspondant aux fonctions téléphoniques;
- les menus de programmation, permettant d'adapter l'appareil à vos besoins.

**Affichage au repos** A l'état de repos, il y a sur l'affichage quelques symboles, qui un indicateur de la qualité de liaison ainsi que la date et l'heure ou un texte individuel de repos (par ex. nom, département, nr. tél., etc.). Lors d'un appel ou dans la phase de conversation, l'affichage passe automatiquement respectivement, au menu "Silence", à "Rétro". "Micro".

→ → → Pressez la touche M (une ou plusieurs brèves impulsions) pour obtenir le menu désiré.

—————→ Avec une longue pression sur la touche M (min. 2 secondes), vous entrez dans le mode de programmation.

—————→ Une longue pression sur la touche Fox sous "☼" inverse le sens de déplacement "☼".

Etat de repos  
Appeler le menu désiré avec la touche M.

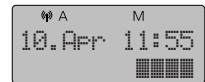

**M** Pressez la touche M une fois.

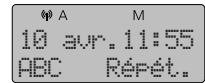

**M** Pressez la touche M une deuxième fois.

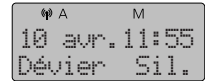

**M** Pressez la touche M une troisième fois.

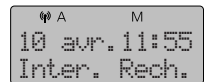

**M** Pressez la touche M une quatrième fois.

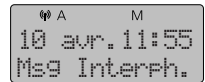

**M** Pressez la touche M une cinquième fois.

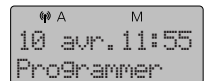

# Consignes de sécurité

Veillez lire attentivement ce mode d'emploi et conservez-le avec soin. Examinez attentivement les consignes de sécurité présentées ci-dessous. L'inobservation de ces prescriptions pourrait vous exposer à des dangers et à des infractions de la législation en vigueur.



## Appareils médicaux

Evitez d'utiliser votre téléphone à proximité de personnes portant des appareils médicaux tels que stimulateur cardiaque ou appareil auditif.



## Disponibilité de communications téléphoniques

La disponibilité du réseau radio n'est pas toujours assurée. Dans une situation critique, ne vous fiez jamais à votre téléphone mobile comme unique moyen de communication.



## Environnement

N'utilisez votre appareil que dans une plage de température comprise entre +5 et +35°C.



Protégez votre appareil de l'humidité, de la poussière, des liquides et vapeurs corrosives.

Evitez d'exposer votre appareil à des champs magnétiques (moteurs électriques, appareils électroménagers), car la qualité de conversation s'en ressentirait. Evitez de le placer à proximité immédiate d'ordinateurs, d'appareils radio, téléviseurs, magnétoscopes et d'autres téléphones afin d'éviter des perturbations.



Evitez d'installer ou d'utiliser votre appareil dans un local présentant un danger d'explosion.



Evitez d'utiliser votre appareil à proximité de travaux de dynamitage. Observez les restrictions et conformez-vous aux directives en vigueur.



## Entretien

Utilisez exclusivement des accessoires d'origine. Ne confiez les travaux d'installation et de maintenance qu'à un spécialiste agréé. Ne touchez pas les contacts enfichables avec un objet métallique ou pointu, et/ou avec des objets gras.

Nettoyez votre appareil avec un chiffon doux, légèrement humide ou antistatique. N'employez à cet effet aucun détergent ni produit chimique quelconque.

# Consignes de sécurité

## Informations importantes

Afin que personne ne puisse effectuer de communications téléphoniques à vos frais avec d'autres téléphones mobiles, il s'effectue continuellement un échange de codes entre l'unité radio et l'appareil portatif. Si les codes ne coïncident pas, la communication est coupée, ou n'est pas établie en premier ressort.

## Blocage du clavier

Vous avez la possibilité de bloquer le clavier de l'appareil portatif pour empêcher toute manipulation intempestive des touches. Avant de procéder à un appel, il vous faudra déverrouiller le clavier.

## Modification du code/mot de passe

Lors de la première mise sous tension de l'appareil portatif, le code/mot de passe est réglé sur "0000". Nous vous conseillons de définir un code personnel comprenant de 2 à 10 chiffres pour protéger votre réglage personnel et éviter l'accès à vos données par toute personne non autorisée.

## Accumulateurs

Deux accus NiMh de format AA (mignon) rechargeables sont fournis avec l'appareil.

- L'emploi de tout autre type d'accumulateurs ou de piles non rechargeables peut se révéler dangereux, et pourrait en outre provoquer le mauvais fonctionnement ou même la détérioration de l'appareil.
- Assurez-vous d'installer les accus à la position correcte!
- Ne plongez jamais les accus dans l'eau, et ne les jetez pas au feu.
- N'utilisez que l'adaptateur secteur fourni avec la station de charge.
- Avant la première mise en service, chargez les accus durant 9 heures au minimum, sans interruption.

## Remarques

- Les accus sont susceptibles de s'échauffer durant la charge, ce qui est normal et ne présente aucun danger.
- Ce n'est qu'après quelques jours d'utilisation que les accus atteignent leur pleine capacité, et par conséquent leur pleine "durée de veille et de conversation".

Après une longue période d'arrêt par coupure du courant (par ex. durant les vacances), l'appareil portatif (les accus) doit être rechargé avant la mise en service. Les accus défectueux doivent être éliminés selon les règles (et ne pas être jetés dans les ordures domestiques).

# Installation et mise en service

## Contenu de l'emballage

L'emballage de l'appareil contient:

- Station de charge
- Appareil portatif
- Clip
- 2 accumulateurs
- Adaptateur secteur
- Mode d'emploi

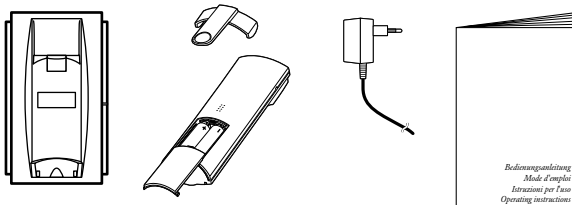

## Raccordement de l'adaptateur secteur

Guidez le câble à travers le canal de décharge de traction prévu à cet effet.

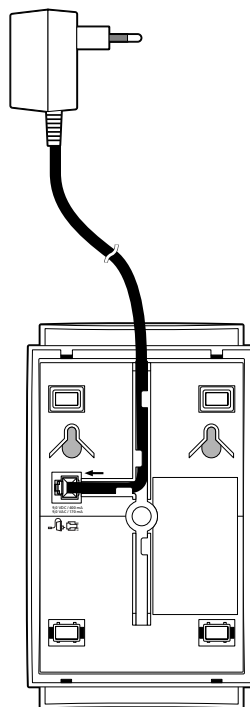

# Installation et mise en service

## Installation de table ou murale, au choix

### Version de table

Le plus simple est d'installer la station de base sur une table. A cet effet, il vous suffit de placer la station en un emplacement judicieux et de la raccorder.

### Version murale

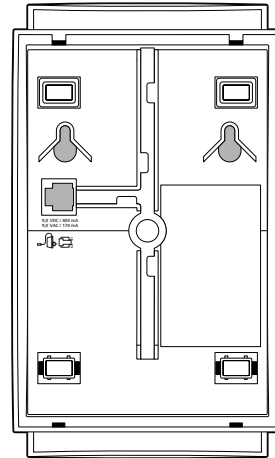
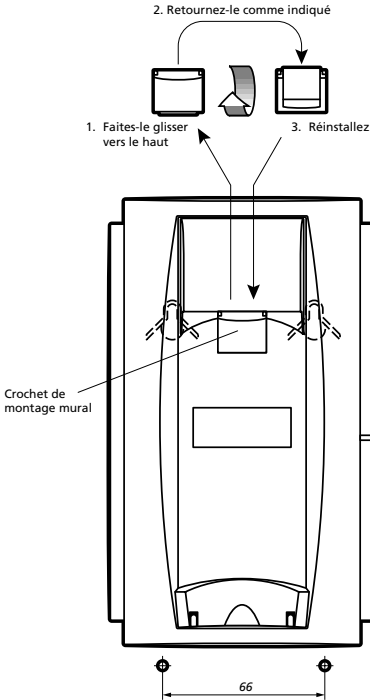

1. Retournez le crochet de montage mural de 180° sur la station de charge (comme sur l'illustration).
2. Permutez les pieds au dos de la station de base (pieds les plus hauts en bas) afin que celle-ci soient parallèle au mur.
3. Percez deux trous pour chevilles (diamètre 5 mm) écartés de 66 mm.
4. Insérez les chevilles.
5. Vissez les deux vis jusqu'à ce que leurs têtes soient écartées d'environ 5 mm par rapport au mur.
6. Accrochez la station de base à ces vis, puis appuyez légèrement vers le bas.

# Installation et mise en service

## Mise en place et charge des accus dans l'appareil portable

### Mise en place des accus

1. Retirez le couvercle du compartiment à accus de l'appareil portable, en le pressant légèrement et en le faisant coulisser vers le bas.
2. Introduisez les 2 accus dans le compartiment (selon l'illustration). Veillez à respecter la polarité des accus, également indiquée dans le compartiment.
3. Glissez le couvercle du compartiment sur les accus et verrouillez-le. Vous devez entendre un déclic.

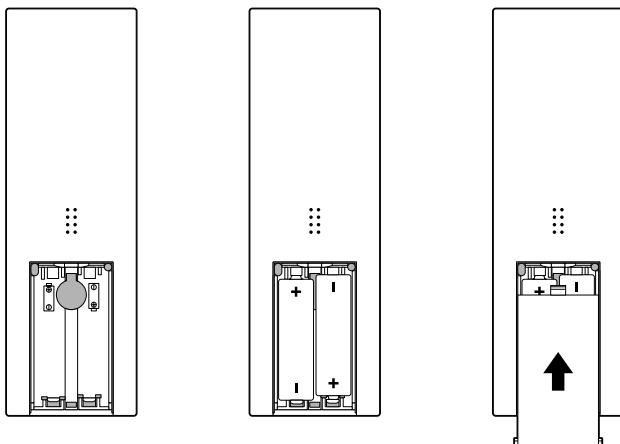

### Charge des accus

A la livraison, les accus ne sont pas chargés. Pour la charge, l'appareil portable doit être placé dans la station de charge.

Le témoin (LED verte) de la station de charge

- clignote = accus en cours de charge
- s'allume = accus chargés

Une charge (1100 mAh-NiMH)

suffit pour env. 60 heures de veille ou  
env. 8 heures de conversation

Durée de charge env. 9 heures

### Remarque

Par une longue pression sur la touche 6, on peut faire afficher le type d'accu et l'état de charge. Après le remplacement de l'accu, on n'obtient qu'après 10-15 minutes de charge une indication fiable de l'état de charge.

# Avant de téléphoner pour la première fois

## Réglage de la langue d'affichage

Normalement, l'appareil est réglé sur la langue utilisée dans le secteur de vente. Si vous désirez utiliser une autre langue, vous pouvez en choisir une parmi celles enregistrées dans le système.



Dans le mode de programmation pressez la touche M autant de fois que nécessaire pour obtenir l'option "\*Langue" (observez le signe "\*" devant une langue étrangère).

Pressez la touche Fox sous "Langue" pour appeler la langue désirée. Pressez la touche Fox sous "☺" autant de fois que nécessaire pour afficher la langue désirée.

Pressez la touche Fox sous "Ok" pour confirmer la langue sélectionnée. La touche C/End permet de retourner au menu précédent.

## Annonce

Vous pouvez annoncer votre appareil mobile auprès d'au maximum 4 PBX (A, B, C, D). Ainsi, vous serez également atteignable via votre appareil mobile lorsque vous vous déplacez dans une autre filiale de votre entreprise.



Dans le mode de programmation, pressez la touche M autant de fois que nécessaire pour obtenir l'option "Système". Pressez la touche Fox sous "Système". "Auto" ou le système actuel (A, B, C ou D) est alors affiché.

Pressez la touche M. Si vous obtenez par exemple "Annonce: A" et "Retirer", l'appareil portatif est annoncé au PBX "A" (vous pouvez effacer cette annonce en pressant la touche Fox sous "Retirer").

L'appareil portatif peut être annoncé auprès de trois autres PBX (B, C ou D) avec la touche Fox sous "☺". L'affichage passe alors à "Annonce: B (C ou D) et "Nouveau". En pressant la touche Fox sous "Nouveau" et "Home", l'appareil est identifié auprès du PBX "B" (à condition que l'opération soit autorisée et que le PBX existe).

# Avant de téléphoner pour la première fois

Nouveau



GAP



Ok



L'appareil portatif peut également être annoncé auprès d'un système PBX tiers avec GAP (Generic Access Profile) au moyen d'un "code".  
Pressez la touche Fox sous "Nouveau" et "GAP", puis donnez le code à la suite de "code:" et confirmez avec la touche Fox sous "Ok".

## Annonce GAP, compatibilité avec d'autres produits DECT

Ascotel DECT soutient toutes les caractéristiques téléphoniques de base, telles que définies dans le standard du Generic Access Profile (GAP) (édition fin 1997). En font partie l'établissement et l'achèvement de communications sortantes et entrantes, la rétrodemande, la numérotation en fréquences (DTMF) et les procédures \*/#. Cela signifie que:

- Votre terminal DECT peut être annoncé et utilisé dans le PBX d'autres fabricants. La condition pour l'utilisation de toutes les caractéristiques téléphoniques de base définies dans le standard GAP est que celles-ci soient complètement installées dans le PBX correspondant.
- Les terminaux DECT d'autres fabricants qui répondent au standard GAP peuvent aussi être annoncés et utilisés dans votre installation. Ils n'offrent cependant qu'une fonctionnalité restreinte du standard GAP et pas la même qualité de liaison radio. En particulier le logiciel pour la gestion de la mobilité avec repérage des déplacements et passation dépend presque à 100% de l'appareil portatif utilisé et il ne peut pas être adapté de manière optimale à votre installation.

## Réglage du système PBX



Système



Dans le mode de programmation, pressez la touche M autant de fois que nécessaire pour obtenir l'option "Système". Pressez la touche Fox sous "Système". "Auto" ou le système actuel (A, B, C ou D) est alors affiché.



Ok



Pressez la touche Fox sous "☒", sélectionnez le système désiré ou "Auto" et confirmez par "Ok". (En position "Auto", si plusieurs systèmes sont disponibles, l'appareil portatif adopte automatiquement le système avec lequel il obtient la meilleure liaison radio.)

## Remarques

- Une longue pression (min. 2 secondes) sur la touche 1 du clavier de numérotation vous permet de passer au système PBX disponible suivant (A, B, C ou D). Si la commutation ne se trouve pas sur "Auto", la sélection manuelle du système PBX est obligatoire pour que votre appareil portatif puisse fonctionner au sein du nouveau système.
- Avec une longue pression sur la touche 2 on obtient l'affichage de l'International Portable Equipment Identity (IPEI) et du PARK (Portable Access Right Key).
- Avec une longue pression sur la touche 5 on obtient l'affichage de la version logicielle de l'appareil portatif avec la date.

# Pour téléphoner

## Répondre à un appel

Un appel est signalé sur l'appareil portable.



Si l'appareil portable se trouve hors de la station de charge, répondez en pressant la touche de conversation.

Ou

L'appareil portable est placé dans la station de charge. Lorsqu'il est soulevé, l'appel est répondu immédiatement (voir "Pour programmer l'appareil" et "Prise directe").

## Interception d'un appel

Sous "Interceptor" le système vous offre les options "Interceptor: Abonné", "Interceptor: Recherche", et "Interceptor: Appel circulaire (RS)". Si vous voulez par exemple répondre avec votre appareil portable à un appel destiné à un abonné actuellement absent, pressez la touche M autant de fois que nécessaire jusqu'à l'apparition de "Interceptor". Presser la touche Fox à cet endroit, puis pressez sous "Interceptor: Abonné", composez le numéro de l'abonné appelé et pressez la touche Fox sous "Ok".

## Conversation

Durant une conversation, la touche M vous permet d'exécuter d'autres fonctions, telles que par exemple introduire une rétrodemande, couper le microphone ("Micro"), régler le volume sonore dans le combiné de "Faible" à "Fort" (ou vice versa).



Pressez la touche M une ou plusieurs fois pour exécuter d'autres fonctions.

## Fin d'une conversation

Pour mettre fin à une conversation, pressez la touche de conversation ou replacez l'appareil portable dans la station de charge. Bien entendu, votre interlocuteur peut également couper la communication. Après un bref instant, l'appareil portable retourne à l'état de repos.

## Réglage du niveau sonore dans l'écouteur et du haut-parleur

Le niveau sonore peut être réglé de manière permanente sur «Fort» ou «Faible» par menu.



Faible



Fort



Pressez la touche M autant de fois que nécessaire pour obtenir "Fort". Pressez la touche Fox sous "Fort".

## Remarque

Les réglages effectués restent conservés même à la fin de la conversation.

# Pour téléphoner

## Numérotation avec préparation

La préparation de la sélection réduit le risque de communications erronées. Avant de presser la touche de conversation, composez le numéro désiré. Vérifiez le numéro et si nécessaire corrigez avec la touche C/End. La communication sera établie dès que vous aurez pressé la touche de conversation.

## Numérotation de chiffres

Ceci correspond au mode de numérotation habituel. Cependant, la communication sera uniquement établie une fois que vous aurez pressé la touche de conversation.



Composez le numéro et pressez la touche de conversation.

## Répétition de la numérotation

La mémoire de répétition enregistre le numéro ou le nom des 10 derniers abonnés que vous avez appelés.



Répét.



Pressez la touche M.  
Pressez la touche Fox sous "Répéter". Le numéro, et le cas échéant le nom du dernier abonné appelé sont alors affichés.



Pressez la touche Fox sous "☒" autant de fois que nécessaire pour obtenir l'abonné désiré, puis pressez la touche de conversation.

## Remarque

Le symbole i indique la disponibilité d'informations supplémentaires, que vous pouvez afficher en pressant la touche i.

## Numérotation par Hotkey

Sous la Hotkey peuvent être enregistrés jusqu'à 6 numéros/noms que vous appelez souvent.



Pressez la Hotkey autant de fois que nécessaire pour afficher le nom désiré.

Meier



Pressez la touche Fox sous le nom désiré puis la touche de conversation.

# Pour téléphoner

## Numérotation par le nom depuis un fichier

Il peut exister jusqu'à trois répertoires téléphoniques (fichiers); un répertoire interne (contenant tous les abonnés raccordés au PBX), une liste de numéros abrégés et un fichier privé. Il est possible d'établir la communication désirée en numérotant un nom, sans devoir composer le numéro correspondant.

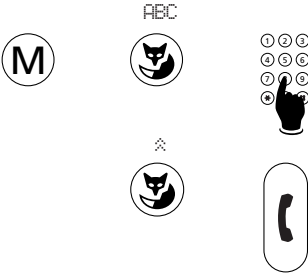

Pressez la touche M. Pressez la touche Fox sous ABC pour obtenir le menu de numérotation de fichier. (Avec "Tous", la recherche s'effectue dans tous les fichiers). Entrer les initiales des noms et prénoms,- par ex. E # A pour Einstein Albert.

En pressant la touche Fox sous "\*", défillez à travers tous les noms et démarrez la procédure de numérotation en pressant la touche de conversation.

### Remarque

L'entrée des initiales est le moyen le plus simple pour composer un numéro enregistré dans un fichier vous n'avez besoin de connaître ni le numéro de téléphone, ni même un numéro abrégé.

Exemple:

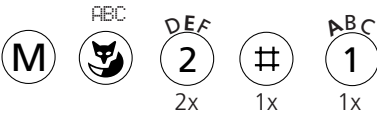

Einstein Albert:  
touche 2: deux fois  
touche #: une fois (produit un espace.)  
touche 1: une fois

Si seul le nom est connu:



Pour corriger un numéro ou un nom composé par préparation, utilisez la touche de correction (effacement du dernier chiffre).



Une longue pression de la touche C met fin à une préparation de numérotation commencée.

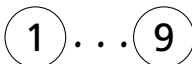

Vous pouvez bien entendu composer un numéro sur votre appareil mobile de la manière habituelle: pressez la touche de conversation puis composez le numéro.

Si vous attendez plus de 10 secondes entre l'entrée de deux chiffres successifs, la sélection est automatiquement interrompue.

# Pour téléphoner

## Liste d'appels

Votre appareil portable enregistre automatiquement dans la liste d'appels le numéro des 10 derniers appels restés sans réponse. Le symbole **i** sur l'affichage attire votre attention sur les appels auxquels vous n'avez pas répondu. Vous pouvez interroger ces numéros et rappeler les correspondants par l'intermédiaire de cette liste.



Appels



Pressez la touche **i** autant de fois que nécessaire pour obtenir "Appels", puis la touche Fox sous "☼" pour défiler jusqu'au numéro désiré.



Effacer



Pressez la touche de conversation pour appeler le numéro affiché ou pressez la touche Fox sous "Effacer" pour effacer l'entrée dans la liste d'appels.

## Coupure du microphone

Durant une conversation, vous désirez échanger quelques mots discrètement avec un collaborateur. A cet effet, vous pouvez couper le microphone de l'appareil portable.

Micro



Pressez la touche Fox sous "Microphone". Le microphone est alors coupé (le symbole "☼" est affiché).

Micro



Pressez une nouvelle fois la touche Fox sous "Microphone" pour réenclencher le microphone.

## Enclenchement de l'appel silencieux

Les appels sur l'appareil portable pourraient vous déranger durant une réunion par exemple. L'enclenchement de l'appel silencieux fait en sorte que les appels seront signalés par un seul signal de sonnerie. Vous pouvez alors identifier l'appelant sur l'affichage et décider si vous voulez répondre ou non. Si vous ne répondez pas, l'appel est placé sur la liste d'appels. L'appel silencieux reste enclenché jusqu'à ce que vous l'ayez supprimé volontairement. Le symbole **i** est présent sur l'affichage pour vous le rappeler.



Sil.



Pressez la touche **M** autant de fois que nécessaire pour obtenir "Silence". Pressez la touche Fox sous "Silence".

## Remarque

L'appel silencieux peut également être enclenché durant un appel. A chaque appel, l'option "Silence" est affichée. Le signal de sonnerie (le signal seulement, mais pas l'appel) est supprimé dès que la fonction "appel silencieux" est activée.

# Pour utiliser les fonctions de confort

## Déclenchement de l'appel silencieux



Désactiver



Pressez la touche **i** autant de fois que nécessaire pour obtenir "Silence" sur l'affichage. Pressez la touche Fox sous "Désactiver" pour déclencher l'appel silencieux.

## Parquer une communication

Durant une conversation, un troisième abonné peut attirer votre attention par un signal d'annonce. Si vous répondez à cet appel, la communication avec le premier interlocuteur est mise en maintien. Pour pouvoir transférer la seconde communication, vous devrez "parquer" la communication mise en maintien.

2. conv



P



Pressez la touche Fox sous "2ème\_conversation" pour rétablir la communication avec l'interlocuteur en attente. Pressez la touche M autant de fois que nécessaire pour afficher "Parquer" (P). Pressez la touche Fox sous "Parquer" pour parquer la communication actuelle.

2ème\_conv.



Pressez la touche Fox sous "2ème\_conversation" pour passer au second interlocuteur. Vous pouvez à présent transférer la communication.

Reprendre



Pressez la touche Fox sous "Reprendre" pour rétablir la communication avec l'interlocuteur en attente.

## Remarque

Contrairement à une communication mise en attente, durant laquelle les deux canaux de conversation disponibles sont tous deux occupés, aucun canal n'est nécessaire pour une communication parquée. Ceci présente l'avantage que vous pouvez transférer un abonné (si nécessaire) ayant émis un signal d'annonce. Si [P] apparaît, une communication est déjà parquée.

## Va-et-vient

Après l'établissement d'une rétrodemande, vous pouvez passer à votre premier interlocuteur tout en conservant la communication en rétrodemande. Vous pouvez ainsi passer d'un interlocuteur à l'autre autant de fois que désiré (va-et-vient).

2. conv



Pressez la touche Fox sous "2ème\_conversation" pour passer au premier interlocuteur.

2. conv



Pressez la touche Fox sous "2ème\_conversation" pour rétablir la communication avec le partenaire de rétrodemande (autant de fois que désiré ou nécessaire).

# Pour utiliser les fonctions de confort

## Transfert d'une communication

Après l'établissement d'une rétrodemande, vous pouvez mettre vos deux interlocuteurs en communication directe.



Pressez la touche de conversation. L'appareil portatif retourne automatiquement à l'état de repos.

## Conférence

Vous avez établi une rétrodemande et désirez maintenant converser en conférence (à trois) avec votre interlocuteur initial.



Pressez la touche M puis la touche Fox sous "Conférence".

## Remarque

N'ayez crainte! Aucune conversation ne peut être perdue lorsque vous établissez une conférence. Les conversations peuvent uniquement être coupées en pressant la touche C ou la touche de conversation.

## Déviation des appels

Vous pouvez dévier les appels qui vous sont destinés vers un autre appareil ou vers l'opératrice, ou laisser une information.



Dévier



Pressez la touche M autant de fois que nécessaire jusqu'à ce que "Dévier" apparaisse, puis la touche Fox sous "Dévier".

Pressez la touche Fox sous "☼" pour défiler jusqu'au type de déviation désiré, par exemple Déviation des appels vers abonné ou Déviation si occupé ou Retransmission des appels vers abonné.



Sélectionnez la destination de la déviation ou, le cas échéant, introduisez un nouveau numéro d'appel.

Confirmez par "Ok".

## Remarque

Si la déviation doit se produire uniquement lorsque vous vous trouvez déjà en communication, sélectionnez "Déviation des appels si occupé" ("DDA si occ. ").

## Mode Twin (présent/absent)

Si en plus de l'appareil portatif vous disposez également d'un appareil raccordé par un fil, ce mode assure votre accessibilité de la manière la plus simple possible. Si le mode Twin est programmé (voir "Comment vous programmez votre appareil"), la déviation d'appel sera activée automatiquement dès que vous sortez l'appareil portatif du chargeur.

# Pour utiliser les fonctions de confort

## Laisser une information pour un appelant

Vous quittez votre place de travail (sans l'appareil portatif) et désirez laisser une information à vos appelants.



Dévier



Pressez la touche M autant de fois que nécessaire jusqu'à ce que "Dévier" apparaisse. Pressez la touche Fox sous "Dévier", puis sous "☼" jusqu'à ce que "DDA info" (Déviation des appels vers information) soit affiché.

Ok



Pressez la touche Fox sous "Ok" puis sous "☼" autant de fois que nécessaire jusqu'à obtenir l'information appropriée (symbole i sur l'affichage).



Pressez la touche i à une ou plusieurs reprises pour afficher la suite de l'information.



Avec la touche C et le clavier, modifiez l'information si désiré (voir "Numérotation par le nom").  
Pressez la touche Fox sous "Ok".

### Remarque

Vous pouvez également effacer complètement une information standard avec la touche C et en composer un nouveau.

## Rappel demandé (exécution d'un rappel)

Un abonné désire vous communiquer une information importante, mais n'a pas réussi à vous joindre. A partir de son appareil de système, il introduit une demande de rappel.

L'affichage de l'appareil portatif contient "Demande rappel", "Activ." et "Eff.".

Activ.



Eff.



Pressez la touche Fox sous "Activer" pour rappeler l'appelant, ou sous "Effacer" si vous considérez que le rappel n'est plus nécessaire.

## Recherche de personnes

Vous désirez atteindre un interlocuteur directement, ou après un essai infructueux via l'installation de recherche de personnes.



Rech.



Pressez la touche M autant de fois que nécessaire jusqu'à ce que la fonction "Recherche" apparaisse. Pressez la touche Fox à cet endroit et composez la numéro de l'interlocuteur recherché.

Ok



Confirmez par "Ok".

# Pour utiliser les fonctions de confort

## Demande de rappel

Vous désirez qu'un interlocuteur occupé ou ne répondant pas vous rappelle.

Rappel



Pressez la touche Fox sous "Rappel". Sur l'affichage apparaît "Appel attendu" et "Désactiver".

Désactiver



Avec la touche Fox sous "Désactiver" vous pouvez désactiver la demande de rappel.

## Remarque

A un moment donné, un seul rappel peut être activé.

## Envoi de messages

Des messages standard sont enregistrés dans le PBX. Après un ou plusieurs appels infructueux, vous pouvez sélectionner l'un de ces messages, le cas échéant le compléter ou le modifier, et l'envoyer à l'abonné concerné ou à un groupe.



Pressez la touche M autant de fois que nécessaire pour obtenir "Message" puis la touche Fox sous cette fonction.

Pressez la touche Fox sous "\*" autant de fois que nécessaire jusqu'à obtenir le message approprié (symbole i sur l'affichage).



Pressez la touche i à une ou plusieurs reprises pour afficher le reste du message.



Avec la touche C et le clavier, modifiez le message si désiré (voir "Numérotation par le nom").

Pressez la touche Fox sous "Ok".



Sélectionnez le numéro de l'abonné/du groupe auquel le message est destiné. Pour envoyer le message, pressez la touche Fox sous "Ok".

## Remarques

- La procédure peut également être effectuée avec préparation de la numérotation, c'est-à-dire en introduisant le numéro puis en sélectionnant le message.
- Vous pouvez également effacer complètement un message standard avec la touche C et en composer un nouveau.

# Pour utiliser les fonctions de confort

## Lecture de messages

Si vous avez reçu un message, l'affichage indique "Message", le numéro de l'expéditeur ainsi que les options "Lire" et "Effacer".

Lire



Pressez la touche Fox sous "Lire". Le signe "+" indique que des informations supplémentaires sont disponibles.



Pressez la touche "i" pour obtenir la ligne suivante.

A la fin du message, l'affichage retrouve les options initiales "Lire" et "Effacer".

Effacer



Pressez la touche Fox sous "Effacer".

## Remarque

Pour que d'autres messages (éventuellement reçus) soient présentés, il faut effacer celui que l'on vient de lire.

## Interphone

A partir de l'appareil portatif, vous pouvez vous adresser directement à un ou plusieurs abonnés, à la condition cependant qu'ils soient équipés d'un appareil de système avec haut-parleur.



Interph.



Pressez la touche M autant de fois que nécessaire pour obtenir "Interphone", puis la touche Fox sous cette fonction.



Groupe



Composez le numéro d'abonné désiré (ou pressez la touche Fox sous "Groupe" et introduisez le numéro de groupe pour diffuser votre message à un groupe d'abonnés prédéfini).

Ok



Pressez la touche Fox sous "Ok" et diffusez votre message.

# Pour utiliser les fonctions de confort

## Activation du mode transparent (numérotation en fréquences DTMF)

Durant une communication, il est possible d'activer une fonction au moyen de la numérotation en fréquences, comme par exemple l'interrogation à distance d'un répondeur téléphonique.



Longue pression de la touche \* jusqu'à ce que "DTMF" apparaisse. Composez ensuite la série de symboles pour activer la fonction désirée .

Lorsque cette exécution est terminée:



Pressez la touche C pour remettre le mode transparent hors service.

ou

Désactiver



Pressez la touche Fox sous "Désactiver".

## Introduction et annulation de la rétrodemande

Durant une conversation, votre interlocuteur vous pose une question à laquelle vous ne pouvez répondre. Vous désirez demander une information à un autre collaborateur, sans couper la communication actuelle.



Rétro.



Composez le numéro de l'abonné auquel vous désirez demander une information. Pressez la touche Fox sous "Rétrodemande"; cet abonné est appelé (la communication actuelle est mise en maintien).

Lorsque vous avez obtenu l'information désirée:



Pressez la touche C pour retrouver la communication avec l'interlocuteur en attente.

## Remarque

Si vous pressez la touche de conversation alors qu'un interlocuteur est en attente, une sonnerie continue a lieu durant 10 secondes. Durant ce signal continu, pressez la touche de conversation pour rétablir la communication avec l'interlocuteur en attente.

# Pour programmer l'appareil

## Points à observer lors de la programmation



La programmation fait partie du concept d'utilisation de l'appareil. Avant de commencer à programmer, lisez attentivement le chapitre "Concept d'utilisation" au début de ce mode d'emploi.

## Mode de programmation

Il existe deux façons d'accéder au mode de programmation:

 Longue pression (min. 2 secondes) sur la touche M.

ou

 ...   Programmer

Pressez plusieurs fois sur la touche M jusqu'à obtenir "Programmer", puis pressez la touche Fox sous "Programmer".

## Remarque

L'activation par longue pression dépend du logiciel et du type de PBX.

## Touche de menu

La touche de menu (M) permet de se déplacer sur deux niveaux: d'abord au niveau des menus de programmation (sélectionnez PRG 1- puis le domaine à programmer, par ex. "touches") puis au niveau de la sous-fonction (par exemple mémorisation d'une touche de numéro). Ces deux niveaux peuvent être quittés en pressant la touche C ou la touche de conversation.

## Enregistrer

Le contenu que vous avez entré ou modifié sous une option donnée est enregistré par pression de la touche Fox sous "Ok". Si vous pressez une autre touche, la programmation faite préalablement n'est pas enregistrée.

# Pour programmer l'appareil

## Aperçu des menus

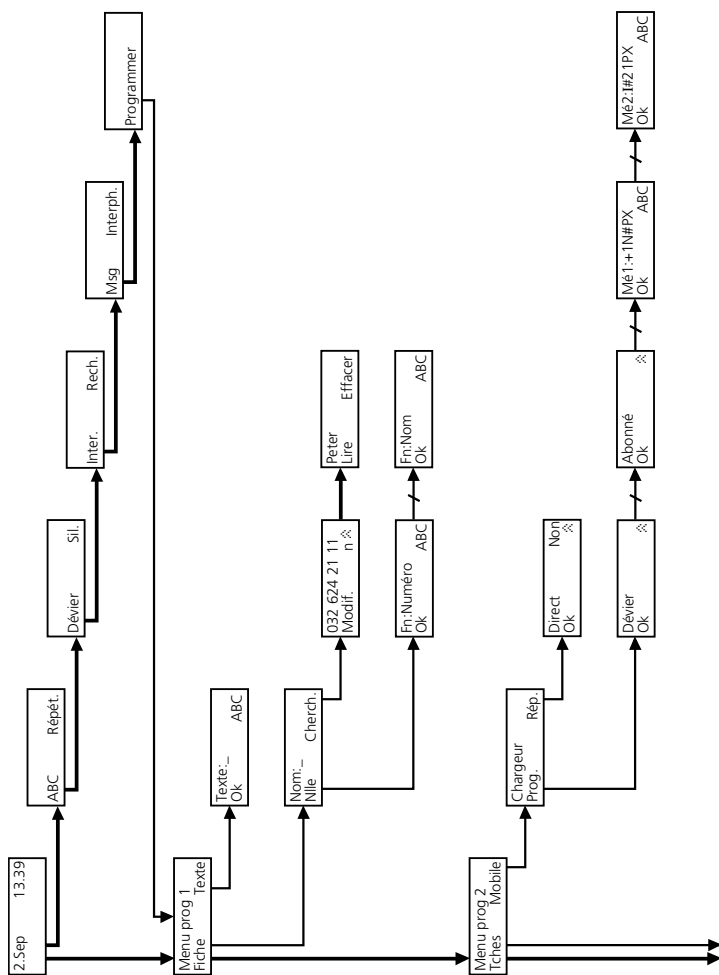

# Pour programmer l'appareil

## Aperçu des menus (suite)

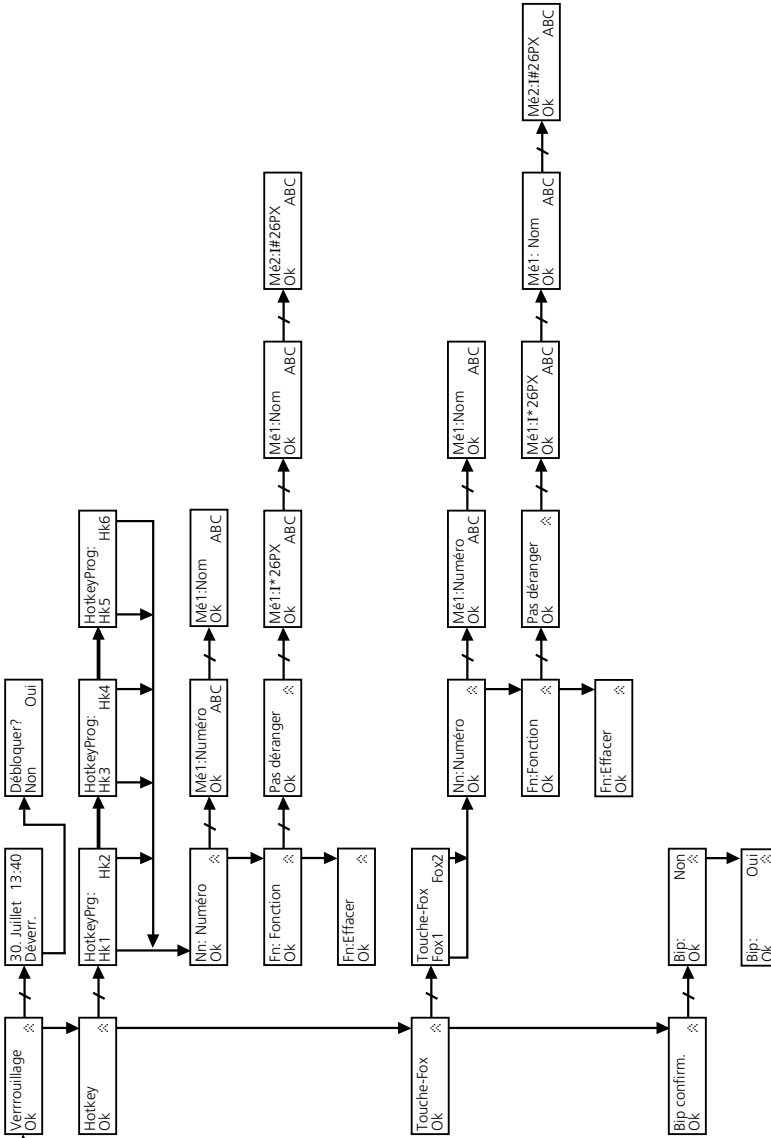

# Pour programmer l'appareil

## Aperçu des menus (suite)

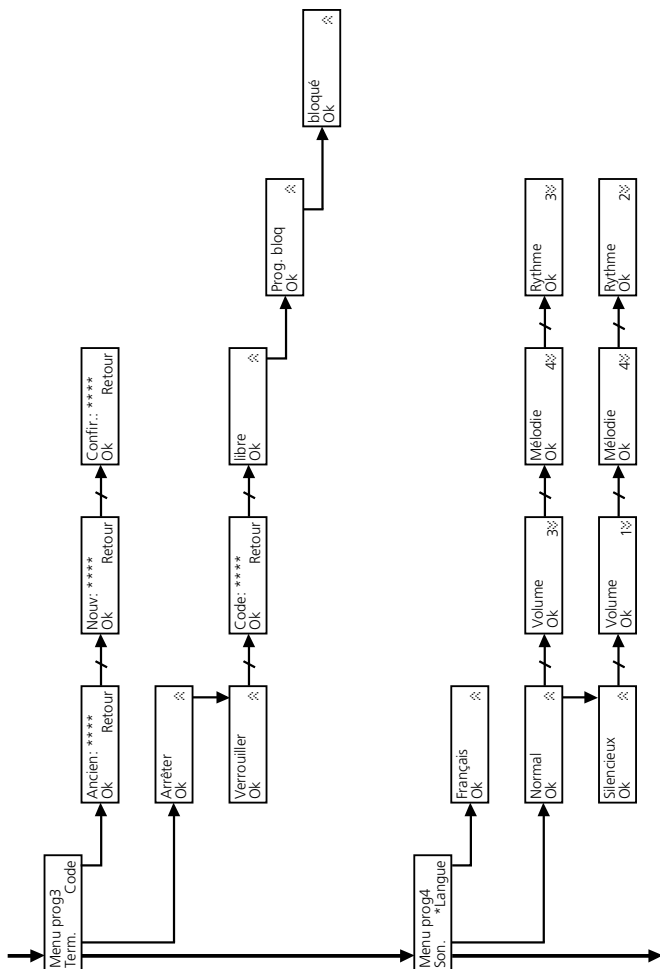



# Pour programmer l'appareil

## Mode Twin (présent/absent)

Si en plus de l'appareil portable vous disposez également d'un appareil raccordé par un fil, ce mode assure votre accessibilité de la manière la plus simple possible.

Le contact de charge détecte 2 états:

- Appareil portable dans la station de charge (présent)
- Appareil portable hors de la station de charge (absent)

La fonction déviation automatique des appels (DDA) est programmée suivant ces états. La déviation a lieu vers l'appareil portable dès que celui-ci ne se trouve plus dans la station de charge.

Une fois l'appareil portable replacé dans la station de charge, la déviation est automatiquement déclenchée.

### Remarque

Des fonctions autres que le mode Twin peuvent être programmées suivant ces 2 états (voir instructions de programmation, menu "Mobile").

### Activer le mode Twin

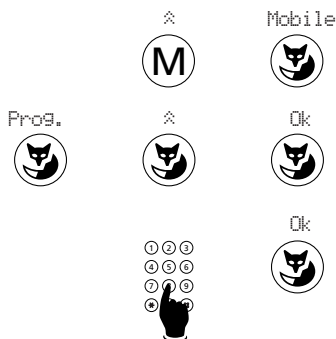

En mode programmation, presser la touche M jusqu'à ce que „Mobile“ apparaisse. Presser sur la touche Fox sous "Mobile".

Presser sur la touche Fox sous "Prog.", puis feuilleter avec la touche Fox sous "❖" jusqu'à "Twin" et confirmer avec "Ok".

Entrer sous "TwinNr:" le numéro de raccordement du terminal relié par fil sur lequel l'appareil portable doit être dévié. Activer le mode Twin avec la touche Fox sous "Ok".

### Désactiver le mode Twin



En mode de programmation, presser la touche M jusqu'à ce que "Mobile" apparaisse. Presser sur la touche Fox sous "Mobile".









Presser sur la touche Fox sous "Prog.", puis feuilleter avec la touche Fox sous "❖" jusqu'à "Aucune fonct." et désactiver le mode Twin avec la touche Fox sous "Ok".

### Remarques

- Si, sur le terminal relié par fil, une déviation (DDA ou RDA) a été volontairement activée vers la secrétaire, vers la boîte vocale ou vers un propre appareil GSM, pendant que l'appareil portable se trouve dans la station de charge, celui-ci aura une priorité plus forte que le mode Twin. Il ne se fait aucune déviation automatique vers l'appareil portable si ce dernier est sorti de la station de charge. Le mode Twin sera de nouveau activé dès que la déviation activée sur le terminal relié par fil aura été désactivée.
- Des fonctions autres que le Mode Twin peuvent être programmées ces 2 états (voir instructions de programmation, menu "Mobile").

## Fichier privé

Outre le répertoire des abonnés du PBX et la liste des numéros abrégés, vous disposez d'un fichier privé qui vous permet de mémoriser jusqu'à 30 numéros et noms. Vous pouvez protéger vos données privées en verrouillant les fonctions de programmation.

		Dans le mode de programmation, pressez la touche M autant de fois que nécessaire pour obtenir "Fiche".
		Pressez la touche Fox sous "Fiche" puis pressez-la sous "Nouvelle" ("Nlle") ou "Chercher" ("Cherch.>").
Nlle		
		Avec "Nouvelle", la prochaine fiche libre est appelée. Composez le numéro et le nom et mémorisez-les avec "Ok".
		
Cherch.		Avec "Chercher", défilez jusqu'à l'entrée désirée en pressant la touche Fox sous "❖".
Modif.		
		Pressez la touche Fox sous "Modifier", modifiez la fiche et mémorisez avec la touche Fox sous "Ok".

## Remarques

- Lorsqu'une fiche est déjà remplie, l'entrée actuelle est affichée. Vous pouvez bien entendu la modifier.
- Il est conseillé de compléter chaque numéro par un nom, car cela simplifie la recherche et la numérotation alphanumérique.
- Si lors d'un appel le numéro de l'appelant est affiché (CLIP), le système recherche ce numéro au sein des répertoires et du fichier privé. Si ce numéro y est enregistré avec le nom correspondant, ce nom est également affiché.

# Pour programmer l'appareil

## Langage macro

Le langage macro permet d'enregistrer plusieurs fonctions successives sous une même touche.

I	Prendre la ligne
X	Libérer une communication
P	Pause (1 seconde)
N	Insérer un numéro composé en mode de préparation
.	Fonction de touche de commande
Z	Mise en/hors service du mode transparent
R	Utiliser le dernier numéro composé

Exemple:

I201 Prendre la ligne et appeler le 201

I\*21201X Prendre la ligne, dévier les appels vers le 201 et libérer la communication

## Programmation du texte affiché au repos

Au lieu de la date et/ou de l'heure, vous pouvez définir un texte personnel qui sera affiché au repos sur votre appareil portatif.

Texte



Dans le mode de programmation, pressez la touche Fox sous "Texte" et introduisez le texte (max. 12 caractères).

Ok



Pressez la touche Fox sous "Ok" pour enregistrer ce texte.

End



Modification du texte affiché au repos (si désiré). La touche de correction (C) permet d'effacer les caractères situés à gauche du curseur.

Ok



Après l'édition, enregistrez le texte en pressant la touche Fox sous "Ok".

## Remarque

Une longue pression sur la touche C/End (min. 2 secondes) a pour effet un retour au menu précédent.

## Blocage et déblocage du clavier

Vous pouvez bloquer le clavier contre toute manipulation intempestive. Les appels sont signalisés et peuvent être pris par pression de la touche de conversation. Après la conversation, on peut en l'espace de 5 s établir une communication sortante. Après 5 s, le blocage des touches (variante 1) sera de nouveau activé.



Tches



Ok



Dans le mode de programmation, pressez la touche M autant de fois que nécessaire pour obtenir "Touches".

Pressez la touche Fox sous "Touches". L'affichage passe alors à "Verrouillage".

Activez le blocage du clavier en pressant la touche Fox sous "Ok".

L'affichage passe alors à "Déverrouiller".

Déverr.



Pressez la touche Fox sous "Déverrouiller". Avec "Deverr.?", l'appareil portable demande confirmation de la désactivation du blocage du clavier.

Oui



Si vous répondez par "Oui", vous obtenez l'affichage au repos; l'appareil est à nouveau opérationnel.

## Remarques









- Avec une longue pression sur la touche 8 (min. 2 secondes), on peut enclencher également la variante 1 du blocage des touches.
- Avec une longue pression sur la touche 9, on peut enclencher la variante 2 du blocage des touches. Celle-ci ne sera pas supprimée automatiquement lors d'un appel, mais elle doit se faire manuellement (voir plus haut), afin de pouvoir recevoir l'appel avec la touche de conversation.

# Pour programmer l'appareil

## Programmation de la touche Hotkey

La Hotkey est une touche librement programmable sous laquelle vous pouvez enregistrer jusqu'à 6 numéros/noms ou fonctions. A l'aide du langage macro, vous êtes en mesure de définir des procédures complètes.

### Enregistrement de numéros/noms sous la Hotkey

- |   |  |   |
|---|--|---|
|    | Touche  | Dans le mode de programmation, pressez la touche M autant de fois que nécessaire pour obtenir "Touches".<br>Pressez la touche Fox sous "Touches".                   |
|    | Ok      | Pressez la touche Fox sous "❖" jusqu'à l'apparition de "Hotkey" et pressez la touche Fox à cet endroit; vous obtenez "HotkeyPrg" et "Hk1", "Hk2".                   |
|    | Ok      | En pressant une ou deux fois la touche M, appelez les mémoires "Hk3" et "Hk4" ou "Hk5" et "Hk6".<br>Sélectionnez la mémoire désirée (Hk1...Hk6) avec la touche Fox. |
|   | Ok      | Dans le menu "Numéro", confirmez une nouvelle fois par "Ok".  |
|  | Ok    | Entrez le numéro et pressez la touche Fox sous "Ok", entrez le nom et pressez la touche Fox sous "Ok" pour enregistrer l'entrée.                                    |

### Remarque

Une longue pression sur la touche Hotkey a pour effet de sauter directement dans le menu de programmation de la touche Hotkey.

# Pour programmer l'appareil

## Enregistrement d'une fonction sous la Hotkey

Procédez de la même manière que pour l'enregistrement du numéro/nom, jusqu'au choix de la mémoire Hk1...Hk6, puis:



Pressez la touche Fox sous "❖" pour appeler le menu "Fn: Fonction" puis confirmer par "Ok".



Pressez la touche Fox sous "❖" autant de fois que nécessaire pour obtenir la fonction désirée puis confirmer par "Ok".



Le contenu de la mémoire 1 (Mé1) est affiché pour cette fonction (activation de la fonction).  
Pressez la touche Fox sous "Ok" pour enregistrer la fonction.



Si vous le souhaitez, entrez le nom et confirmer par "Ok". Le contenu de la mémoire 2 (Mé2) est affiché (désactivation de la fonction).



Enregistrer la fonction avec "Ok".

### Remarques







- Les codes de fonction correspondants sont automatiquement enregistrés dans la mémoire sélectionnée. Au besoin, ceux-ci peuvent être modifiés ou complétés.
- Si aucun nom n'est entré pendant le processus d'enregistrement, un nom abrégé sera utilisé par défaut, par ex. "Pas dér." pour "Ne pas déranger".
- Lorsqu'une fonction programmée est active, le symbole "■" apparaît sur la ligne des symboles, et la fonction correspondante est cochée "☑".
- Une longue pression sur la touche Hotkey a pour effet de sauter directement dans le menu de programmation de la touche Hotkey.

# Pour programmer l'appareil

## Programmation des touches fox

Vous pouvez également utiliser les deux touches fox comme touches librement programmables. Au repos, les numéros ou fonctions fréquemment utilisés sont affichés, et vous pourrez les numéroter confortablement d'une seule pression (sur la touche Fox correspondante). Lorsqu'une fonction est enregistrée sous une touche Fox, le symbole "f" est affiché à l'état actif.

## Enregistrement d'un numéro/nom ou d'une fonction sous une touche Fox





	Tches 	Dans le mode de programmation, pressez la touche M autant de fois que nécessaire pour obtenir "Touches". Pressez la touche Fox sous "Touches".
	✳ 	Pressez la touche Fox sous "✳" autant de fois que nécessaire pour obtenir "Touche_fox".
	Ok 	Pressez la touche Fox sous "Ok" puis la touche désirée "Fox 1" ou "Fox 2".
Fox 1 	Fox 2 	Poursuivez comme indiqué sous "Programmation de la touche Hotkey".

## Remarques

- Une longue pression sur la touche Fox a pour effet de sauter directement dans le menu de programmation de la touche Fox.
- Si les deux touches Fox sont occupées par un numéro ou une fonction **et** un nom, l'affichage de la qualité de liaison disparaît.
- L'affichage de la qualité de liaison reste maintenu si, pour la touche Fox 1 ou 2, on a entré, au lieu d'un nom, un espace avec la touche #.

## Tonalité de confirmation des touches

Si désiré, l'appareil portatif peut confirmer chaque pression de touche par l'émission d'une tonalité.

	Tches 	Dans le mode de programmation, pressez la touche M autant de fois que nécessaire pour obtenir "Touches".
✳ 	Ok 	Pressez la touche Fox sous "Touches". Pressez la touche Fox sous "✳" jusqu'à obtenir "Bip confirmation" et confirmez par "Ok".
✳ 	Ok 	Avec la touche Fox sous "✳", sélectionnez "Bip: Non" ou "Bip: Oui". Pressez la touche Fox sous "Ok" pour enregistrer ce réglage.

## Remarque

Le placement de l'appareil portatif dans la station de charge est toujours confirmé par une brève tonalité.

# Pour programmer l'appareil

## Réponse directe (sans touche de conversation)

Si l'appareil portatif est réglé sur "Direct", le fait de le soulever de la station de charge répond automatiquement à un appel, sans devoir presser la touche de conversation.

Le placement de l'appareil portatif dans la station de charge ("Raccrocher") libère toujours la communication si cela n'avait pas été fait préalablement en pressant la touche de conversation.

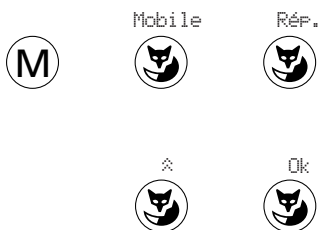

Dans le mode de programmation, pressez la touche M autant de fois que nécessaire pour obtenir "Mobile". Pressez la touche Fox sous "Mobile" et puis sous "Répondre".

Avec la touche Fox sous "❖", changer à "Direct: Oui". Avec la touche Fox sous Ok, confirmez le réglage "Direct: Oui".

## Enclenchement/déclenchement de l'appareil portatif

### Déclenchement



Dans le mode de programmation, pressez la touche M autant de fois que nécessaire pour obtenir "Terminal".



Pressez la touche Fox sous "Terminal". Vous obtiendrez "Arrêter".

Pressez la touche Fox sous Ok pour déclencher l'appareil. La liaison avec l'unité radio est coupée (pas d'affichage).

### Remarques

- Une longue pression (min. 2 secondes) sur la touche 0 du clavier permet également de déclencher l'appareil.
- En dehors de la portée radio, l'appareil portatif tente continuellement d'établir une liaison avec une unité radio. Afin de protéger la batterie, il est conseillé de déclencher l'appareil lorsqu'on quitte la portée durant une période prolongée.

### Enclenchement



Presser sur la touche de conversation et enclencher l'appareil avec la touche Fox sous "Oui".

# Pour programmer l'appareil

## Verrouillage/déverrouillage de l'appareil portatif

Vous pouvez bloquer l'appareil portatif contre tout emploi abusif. Le gestionnaire du système peut vous renseigner sur les communications (par ex. numéros d'urgence) pouvant être établies malgré ce verrouillage.

A l'état verrouillé, vous pouvez à tout moment prendre un appel avec la touche de conversation. Avant d'effectuer un appel sortant, l'appareil portatif devra cependant être déverrouillé.

Il est conseillé de bloquer les fonctions de programmation de l'appareil portatif avec "Programmation bloquée". Vous protégerez ainsi les entrées de votre fichier privé.



Dans le mode de programmation, pressez la touche M autant de fois que nécessaire pour obtenir "Terminal". Pressez la touche Fox sous "Terminal". Vous obtiendrez "Arrêter".

Sélectionnez "Verrouiller" avec la touche Fox sous "❄", pressez "Ok" et introduisez votre code (mot de passe).

Pressez la touche Fox sous "Ok" pour vérifier le mot de passe.

Avec la touche Fox sous "❄" sélectionnez "libre", "Programmation bloquée." ou "bloqué" (Sur "libre", le blocage est supprimé.) et confirmez avec la touche Fox sous "Ok".

## Modification du code/mot de passe

Lors de la première mise sous tension de l'appareil portatif, le code/mot de passe est réglé sur "0000". Nous vous conseillons de définir un code personnel comprenant de 2 à 10 chiffres pour protéger votre réglage personnel et éviter l'accès aux données enregistrées par toute personne non autorisée (modification, effacement).

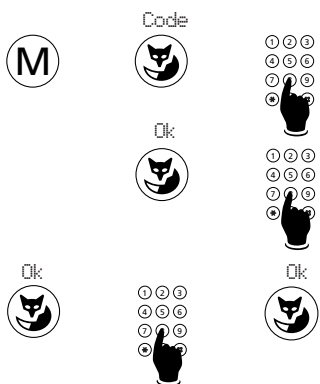

Dans le mode de programmation, pressez la touche M autant de fois que nécessaire pour obtenir "Code". Pressez la touche Fox sous "Code" et introduisez le code actuel.

Pressez la touche Fox sous "Ok" et introduisez le nouveau code.

Pressez la touche Fox sous "Ok"; il apparaît: "Confirmation:" Introduisez le code une seconde fois et confirmez avec la touche Fox sous "Ok".

## Réglage du signal de sonnerie (appel normal et silencieux)

L'appareil portable est capable de signaler un appel avec des volumes sonores, mélodies et cadence (rythme) réglables. Vous pouvez régler le type de signal de sonnerie qui vous convient et ainsi reconnaître facilement si l'appel vous est destiné, ou le cas échéant s'il provient de l'appareil portable de votre voisin.

Avec "Silence", un appel est signalisé au moyen d'un unique signal de sonnerie.



Dans le mode de programmation, pressez la touche M autant de fois que nécessaire pour obtenir "Sonnerie" (Son.).

Son.



Pressez la touche Fox sous "Sonnerie" et avec la touche Fox sous "❖" sélectionnez "Normal" ou "Silencieux".

Ok



Pressez la touche Fox sous "Ok" pour mettre en service le signal de sonnerie actuel.



Pressez la touche Fox sous "❖" autant de fois que nécessaire pour obtenir le volume désiré.

Ok



Pressez la touche Fox sous "Ok" pour enregistrer le réglage et dans le prochain menu sélectionner une mélodie avec la touche Fox sous "❖".

Ok



Ok



Après enregistrement de la mélodie désirée par "Ok", pressez la touche Fox sous "❖" dans le menu "Rythme" pour régler le rythme des signaux de sonnerie et confirmer avec la touche Fox sous "Ok".

### Remarque

Avec la touche M, vous pouvez passer librement entre les options "Volume", "Mélodie" et "Rythme" sans enregistrer les modifications éventuelles.

# Dérangements

## Sortie de la portée radio

Lorsque vous sortez de la portée radio, une tonalité d'avertissement retentit et le message "Aucun système" apparaît tandis que le symbole d'antenne (📶) disparaît. Si cela a lieu pendant une conversation, celle-ci sera interrompue, mais la liaison n'est pas immédiatement supprimée. Le système tente ensuite pendant 20 s d'établir une nouvelle liaison radio avec la même unité radio ou une autre. Ensuite seulement la liaison sera supprimée dans le PBX.

Hors de la portée radio, les fonctions de programmation suivantes restent accessibles avec la touche M:

"Programmer", "Tches", "Mobile", "Term.", "Son.", "\*Langue", "Test" et "Système".

## Affichage à l'écran, pas de tonalité de numérotation

L'appareil portatif est peut-être verrouillé (voir "Verrouillage/déverrouillage de l'appareil portatif").

## Les touches Hotkey et Fox ne peuvent pas être programmées

La programmation est peut-être bloquée (voir "Verrouillage/déverrouillage de l'appareil portatif").

## Déverrouillage de l'appareil portatif; oubli du mot de passe

Demandez à l'opératrice d'initialiser votre mot de passe à partir du central.

## Affichages

### "Attendez SVP"

Ce message peut apparaître durant la procédure d'identification. Il apparaît également lorsqu'un interlocuteur a placé la communication en maintien.

### "Term. inconnu"

L'identification de l'appareil portatif auprès du PBX a échoué. Interrogez le gestionnaire de votre système.

### "Surcharge"

Aucune ressource disponible, veuillez attendre et essayer à nouveau.

### "System Busy"

Aucune liaison ne peut être établie momentanément par l'unité radio actuelle. L'appareil portatif tente d'établir une meilleure liaison radio avec la même unité radio ou une autre. Le message n'apparaît qu'à l'état de repos.

### "Hors système"

Vous avez quitté la portée radio; la liaison avec le PBX est interrompue.

### "Annonce"

Procédure d'identification auprès du PBX en cours.

### "En panne" / signal de sonnerie permanent progressif

Chaque fois que l'appareil portatif est posé dans le chargeur, ses paramètres sont vérifiés. Si une erreur de paramètre est constatée, un signal acoustique de défectuosité retentit et sur l'écran apparaît "En panne". L'appareil portatif doit être renvoyé au fournisseur pour réparation ou échange.

## Remarque

Si d'autres messages de dérangement apparaissent, interrogez le gestionnaire de votre système.

# Codes de fonction

## Quels chiffres faut-il composer?

Sélection normale	Séquence de touches
<b>Interphone de porte</b> .....	851... 852 <sup>1)</sup> .....
<b>Numéro de secours</b> .....	12 .....
<b>Numéros abrégés PBX</b> .....	7000...7999 <sup>1)</sup> .....
<b>Opératrice</b> .....	11 .....
<b>Raccordements collectifs</b> .....	860... 888 <sup>1)</sup> .....
<b>Sortie réseau</b>	
société .....	0 .....
privé .....	10 .....
avec compte de frais .....	13 no-compte .....
<b>Voie d'acheminement</b> .....	170... 199 <sup>1)</sup> .....
<hr/>	
<b>Postsélection</b>	
<b>Appel codé</b> .....	8 ou *81
<b>Conférence</b>	
établir à partir d'une communication .....	3
exclure les abonnés internes .....	*31
<b>Demande rappel no. / MESSRÉE</b>	
activer l'affichage .....	*38
<b>Intercalation</b> .....	7 ou *44
refuser .....	0
répondre avec maintien .....	2
répondre sans maintien .....	1
<b>Parcage d'une communication</b> .....	*76
<b>Rappel automatique (activer)</b>	
en cas d'abonné occupé .....	9 ou *37
en cas d'abonné absent .....	9 ou *37
<b>Recherche de personnes</b> .....	8 ou *81
<b>Retour à la 1<sup>ère</sup> communication</b> .....	1
<b>Signal d'annonce</b> .....	6 ou *43
refuser .....	0
répondre avec maintien .....	2
répondre sans maintien .....	1
répondre avec conférence .....	3

1) La définition et le domaine des numéros sont spécifiques au central et au logiciel

# Codes de fonction

**Transfert des taxes sur un compte de frais** ..... \*78 no-compte

**Va-et-vient multiple** (commuter entre deux communications) ..... 2

## Présélection

---

**Annuler le rappel automatique** ..... #37

**Appel circulaire** (répondre) ..... \*83

### Appel codé

activer ..... \*81 no-abonné

répondre ..... \*82

### Appel d'échéance

 (demande de réveil)<sup>2)</sup>

activer ordre permanent ..... \*56 hh mm

désactiver ordre permanent ..... #56

activer ordre unique ..... \*55 hh mm

désactiver ordre unique ..... #55

### Communication

parquer ..... \*76

reprenre la communication parquée ..... #76

### Conférence

variable ..... \*71 no-abo. 1\*

... no-abo.5#<sup>1)</sup>

prédéterminée ..... \*70 no-conférence

### Connexion de jour, de nuit et de fin de semaine

 (groupe de commutation 1)

jour (position 1) ..... \*8511

nuit (position 2) ..... \*8512

fin de semaine (position 3) ..... \*8513

### Courtesy (message d'accueil)

enclencher groupe 1 ..... \*931

déclencher groupe 1 ..... #931

enclencher groupe 2 ..... \*932<sup>1)</sup>

déclencher groupe 2 ..... #932<sup>1)</sup>

### Demande rappel no. / MESSAGE<sup>2)</sup>

activer l'affichage ..... \*38 no-abonné

effacer la destination ..... #38 no-abonné

### Désactiver toutes les fonctions activées<sup>2)</sup>

(excepté raccordement collectif) ..... \*00

### Déviatoin des appels DDA

se protéger contre DDA<sup>2)</sup> ..... \*02

autoriser DDA vers soi<sup>2)</sup> ..... #02

1) La définition et le domaine des numéros sont spécifiques au central et au logiciel

2) La télécommande est possible

activer DDA inconditionnelle <sup>2)</sup> .....	*21 no-destination
désactiver DDA inconditionnelle <sup>2)</sup> .....	#21
activer DDA inconditionnelle vers dernier numéro prog. ...	*21#
désactiver DDA inconditionnelle vers dernier no. prog. ....	#21
activer DDA vers le numéro préprogrammé <sup>2)</sup> .....	*22
désactiver DDA vers le numéro préprogrammé <sup>2)</sup> .....	#22
activer DDA si occupé <sup>2)</sup> .....	*67 no-destination
désactiver DDA si occupé <sup>2)</sup> .....	#67
activer DDA si occupé vers dernier numéro progr. ....	*67#
désactiver DDA si occupé vers dernier numéro progr. ....	#67
activer DDA vers information standard <sup>2)</sup> .....	*24 no-texte#
désactiver DDA vers information standard <sup>2)</sup> .....	#24
activer DDA vers recherche de personnes IRP ou vers sonnerie circulaire avec appel codé <sup>2)</sup> .....	*28
désactiver DDA sur recherche de personnes IRP ou vers sonnerie circulaire avec appel codé <sup>2)</sup> .....	#28

## Follow me

activer .....	*23 no-abonné
effacer .....	#23

## Groupe de commutation (entrant)

groupe de commutation x, pos. 1 .....	*85x1
groupe de commutation x, pos. 2 .....	*85x2
groupe de commutation x, pos. 3 .....	*85x3
remarque: x est un chiffre entre 2 et 9 .....	

## Intercalation <sup>2)</sup>

se protéger contre .....	*04
l'autoriser .....	#04

## Interception d'appel .....

\*86 no-abonné

## Interphone

à un abonné .....	*7998 no-abonné
à un groupe .....	*79 no-groupe
répondre dans un groupe .....	*89

## Messages (messages standard avec/sans paramètre) <sup>2)</sup>

envoyer à un abonné .....	*3598 no-abo. no-texte#
envoyer à un groupe .....	*35 no-groupe no-texte#
envoyer à tous .....	*3599 no-texte#

## Ouvrir les portes .....

\*751/\*752 <sup>1)</sup>

## Raccordement collectif <sup>2)</sup>

s'insérer .....	*48
se retirer .....	#48

1) La définition et le domaine des numéros sont spécifiques au central et au logiciel

2) La télécommande est possible

# Codes de fonction

## Recherche de personnes

chercher .....	*81 no-abonné
répondre (avec une voie de recherche) .....	*82
répondre (avec plusieurs voies de recherche) .....	*82 no-abonné

## Relais

enclencher .....	*755...*757 <sup>1)</sup>
déclencher .....	#755...#757 <sup>1)</sup>

## Retransmission des appels RDA (deviation si non réponse)

se protéger contre RDA <sup>2)</sup> .....	*02
autoriser RDA vers soi <sup>2)</sup> .....	#02
activer RDA <sup>2)</sup> .....	*61 no-destination
désactiver RDA <sup>2)</sup> .....	#61
activer RDA vers le dernier numéro programmé .....	*61#
désactiver RDA vers le dernier no. programmé .....	#61
activer RDA vers le numéro préprogrammé <sup>2)</sup> .....	*62
désactiver RDA vers le numéro préprogrammé <sup>2)</sup> .....	#62
activer RDA vers recherche de personnes IRP ou vers sonnerie circulaire avec appel codé <sup>2)</sup> .....	*68
désactiver RDA vers recherche de personnes IRP ou vers sonnerie circulaire avec appel codé <sup>2)</sup> .....	#68

## Signal d'annonce <sup>2)</sup>

se protéger contre .....	*04
le permettre .....	#04

## Sortie réseau

activer avec rappel de taxes .....	*32 no-abonné
------------------------------------	---------------

## Suppression des appels (ne pas déranger) <sup>2)</sup>

activer .....	*26
désactiver .....	#26

## Télécommande

<b>activer</b> (à partir d'un appareil tiers) .....	*06 no-abo. *21 no-dest.
lancer la télécommande / introduire le numéro d'abonné activable à distance / introduire la procédure à * souhaitée (p.ex. *21 no-dest.)	

<b>désactiver</b> (à partir d'un appareil tiers) .....	*06 no-abonné #21
lancer la télécommande / introduire le numéro d'abonné activable à distance / introduire la procédure à # souhaitée (p.ex. #21)	

<b>désactiver</b> (à partir du propre appareil) .....	#21
introduire la procédure à # (p.ex. #21)	

1) La définition et le domaine des numéros sont spécifiques au central et au logiciel

2) La télécommande est possible

## A

ABC 13  
Accumulateurs 5, 8  
Annonce 9  
Appel silencieux 14, 15

## B

Blocage du clavier 5  
Blocage e débloccage du clavier 29

## C

Code/mot de passe 5, 34  
Conférence 16  
Consignes de sécurité 4, 5  
Coupure du microphone 14

## D

Dérangements 36  
Déviation des appels 16  
DTMF 20

## E

Enclenchement/déclenchement 33  
Envoi de messages 18

## F

Fichier privé 27

## H

Hotkey 12, 30, 31

## I

Installation 6, 7, 8  
Interphone 19

## L

"Longue pression" fonctions  
② Affichage de IPEI et PARK 10  
⑧ Blocage des touches (variante 1) 29  
⑨ Blocage des touches (variante 2) 29  
⑩ Déclenchement de l'appareil portatif 33  
⊗ Enclencher la numérotation en fréquences 20  
Ⓜ Mode de programmation 3, 21  
☎ Modifier le sens de déplacement 3  
⑤ Numéro de version logicielle 10

☎ Programmation de la touche Fox 32  
④ Qualité de liaison 2  
Ⓜ Programmation de la touche Hotkey 30, 31  
① Réglage du système PBX 10  
Ⓢ Saut au menu précédent 28  
⑥ Type d'accu et l'état de charge 8

## M

Langage macro 28  
Messages 18, 19  
Mode transparent 20  
Mode Twin 26  
Modification du code/mot de passe 34  
Mot de passe 5, 34

## N

Numérotation avec préparation 12  
Numérotation en fréquences DTMF 20  
Numérotation par Hotkey 12

## P

Parquer une communication 15  
Programmation de la touche Hotkey 30  
Programmer 21

## R

Rappel 17, 18  
Recherche de personnes 17  
Réglage d'appel et d'appel silencieux 35  
Réglage de la langue d'affichage 9  
Réglage du système PBX 10  
Répétition de la numérotation 12  
Réponse directe 33  
Rétrodemande 20

## S

Silencieux 14, 15, 35  
Sortie de la portée radio 36  
Symboles spéciaux 1

## T

Texte affiché au repos 28

## V

Va et vient 15  
Verrouillage/déverrouillage 34

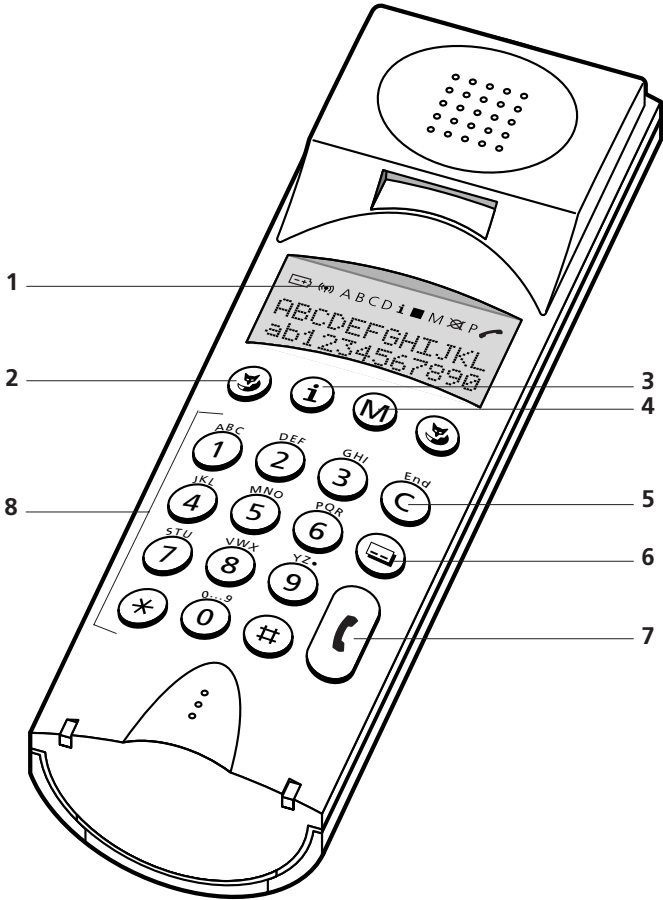

# Comandi e visualizzazioni

## 1 Quadro di visualizzazione (display)

Il display comprende la riga dei simboli, la riga d'informazione e la riga dei menu, ciascuna con 12 simboli/caratteri.

## 2 Tasti Fox

Nella riga più in basso del display viene sempre visualizzata la relativa funzione. Entrambi i tasti Fox possono essere programmati liberamente.

## 3 Tasto **i** (tasto informazioni)

Per richiamare ulteriori informazioni (simbolo **i** attivo)

## 4 Tasto **M** (tasto menu)

Serve a cercare il punto del menu desiderato; è a funzionamento ciclico, ovvero dopo la visualizzazione dell'ultimo punto del menu ricompare il primo (simbolo **M** attivo).

## 5 Tasto **C/End** (tasto di cancellazione/correzione)

Serve per cancellare o correggere (clear) i caratteri introdotti erroneamente. Ritorno al punto del menu precedente o allo stato di riposo.

## 6 Hotkey

Tasto programmabile liberamente per un massimo di 6 numeri/nomi o funzioni.

## 7 Tasto gancio (su/giù)

Ha il medesimo effetto di sollevare/riagganciare il microtelefono. Riaccende l'apparecchio quando è spento.

## 8 Tastierino 0 - 9 (A - Z), \* e #

Introduzione di cifre e selezione delle funzioni comfort con le procedure \*/#. Introduzione di nomi e/o testi nel modo alfa. (il passaggio da cifre a lettere avviene automaticamente dopo la selezione di un corrispondente punto del menu). Esempio: 1 x tasto 2 = D, 2 x tasto 2 = E, 3 x tasto 1 = C, 2 x tasto 7 = T

Se la selezione alfa è attiva il tasto  può generare anche uno spazio.



# Comandi e visualizzazioni

## Simboli speciali del display



Stato di carica dell'accumulatore

Nessuna indicazione: Accumulatore carico, apparecchio pronto  
Simbolo lampeggiante: Accumulatore quasi scarico (avvertimento)  
Simbolo lampeggiante +  
segnale acustico: Accumulatore scarico



Simbolo antenna

Nessuna indicazione: Apparecchio al di fuori della portata massima  
Indicazione continua: Apparecchio pronto per telefonate in entrata e uscita.

ABCD

Indicazione continua: L'apparecchio è registrato nel sistema A (B, C o D) e pronto a funzionare.  
Lampeggiante: L'apparecchio non è pronto.

ABCD

Lampeggiante: L'apparecchio non è stato registrato.

ABC

Indicazione continua: La selezione alfa è attiva

**i**

Informazioni supplementari (da richiamare con il tasto **i**)



Una delle funzioni memorizzate nel tasto Hotkey/Fox è attiva

**M**

Altri menu (da richiamare con il tasto **M**)



Microfono disinserito

**P**

Modo di programmazione



Indicazione continua: Connessione attiva  
Lampeggiante: Segnalazione ottica di una chiamata (p.es. se è stata disattivata la suoneria)

Altri simboli sulla riga d'informazione o dei menu:

12x	Permette di "sfogliare" una lista (con indicazione del numero progressivo della registrazione)
T	Chiamata per un gruppo di utenti
D	Chiamata deviata
f	La funzione è attiva

Qualità del collegamento radio (solo con display in stato di riposo o standby)

■■■■■	Qualità del collegamento ottima
■■■■	Qualità del collegamento buona
■■■	È possibile telefonare, probabili disturbi
■■	Non sempre è possibile telefonare, forti limitazioni
· · · ·	Non è più possibile telefonare

### **Avvertenza**

La qualità del collegamento può essere verificata anche con "Long Click 4". Contemporaneamente viene visualizzato il numero dell'unità radio corrispondente.

# Il metodo di comando: la tecnica a menu

Il vostro nuovo apparecchio cordless può essere programmato secondo le vostre esigenze e, oltre alla mobilità, consente di eseguire tutte le funzioni telefoniche che desiderate. Ciò nonostante, il suo impiego è semplice e facile (intuitivo), grazie all'intelligente tecnica a menu e alla volpe ingegnosa (tasti Fox). Il capitolo "Come programmare il vostro apparecchio" e le istruzioni per la programmazione vi aiutano a sfruttare integralmente le caratteristiche di esercizio del vostro apparecchio.

## Regole generali per l'uso

Ci sono due tipi di menu:

- I menu di uso generale per le funzioni di telefonia.
- I menu di programmazione, per impostare il vostro apparecchio secondo le vostre esigenze.

Quadro di riposo      A riposo nel display appaiono alcuni simboli, il livello di qualità, nonché la data e l'ora oppure un testo personalizzato (ad es. nome, reparto, numero di telefono etc.). In caso di chiamata o in fase di conversazione la visualizzazione passa automaticamente al menu "Discreta" o "Richi." "Micro".

→ → →      Con il tasto M (va premuto una o più volte) si arriva al menu di comando desiderato.

—————→      Tenendo premuto il tasto M per almeno 2 secondi ("Long click") si attiva il modo di programmazione.

—————→      Un "Long Click" del tasto Fox sotto "❖" modifica la direzione di ricerca in "❖".

Stato di riposo  
Richiamate con il tasto M il menu desiderato

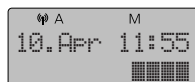

M

Premete una volta il tasto Menu

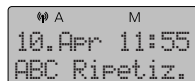

M

Premete una seconda volta il tasto Menu

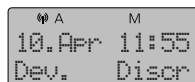

M

Premete una terza volta il tasto Menu

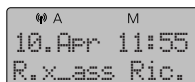

M

Premete una quarta volta il tasto Menu

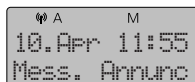

M

Premete una quinta volta il tasto Menu

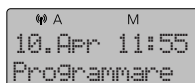

## Avvertenze di sicurezza

Leggere le presenti istruzioni per l'uso e conservarle con cura. Studiate attentamente le seguenti avvertenze di sicurezza. L'inosservanza di queste norme può comportare dei rischi e costituire una violazione delle leggi vigenti.



### Apparecchiature medicali

Il telefono non dovrebbe essere utilizzato nelle vicinanze di apparecchiature medicali personali, come pace-maker o apparecchi acustici.



### Disponibilità del collegamento telefonico

Non sempre può essere garantita la disponibilità della rete di unità radio. Nelle situazioni critiche non fate affidamento sull'apparecchio cordless quale unico mezzo di comunicazione.



### Condizioni d'impiego

Usate il vostro apparecchio solo con temperature da +5 °C fino a +35 °C. Evitate la luce diretta del sole e altre fonti di calore.



Tenete il vostro apparecchio al riparo dall'acqua, dalla polvere, da liquidi e vapori aggressivi.

Non esporre il vostro apparecchio a campi elettromagnetici (motori elettrici, elettrodomestici), la qualità della voce potrebbe peggiorare. Evitate di usare l'apparecchio nelle immediate vicinanze di computer, apparecchi radio, TV, video e telefoni per evitare disturbi.



Non installate né utilizzate mai l'apparecchio in locali con rischio di esplosione.



Non usare mai l'apparecchio vicino ai posti in cui si lavora con esplosivi. Osservare le limitazioni imposte e le prescrizioni in materia.



### Manutenzione

Utilizzate esclusivamente accessori originali. Installazioni e riparazioni devono essere eseguite sempre da un tecnico qualificato.

Non toccate i contatti per la ricarica dell'accumulatore con oggetti acuminati, metallici e/o unti.

Pulite l'apparecchio con un panno morbido, leggermente umido o antistatico.

Non utilizzate detersivi né altre sostanze chimiche.

# Avvertenze di sicurezza

## Informazioni importanti

Per evitare che altre persone possano telefonare abusivamente a vostre spese con altri apparecchi, l'unità radio e l'apparecchio portatile scambiano periodicamente dei segnali d'identificazione. Se i segnali d'identificazione non corrispondono, il collegamento viene interrotto, oppure non viene nemmeno stabilito.

## Blocco e sblocco della tastiera

Potete bloccare il vostro apparecchio in modo da evitare che i tasti vengano azionati involontariamente. Potete comunque rispondere alle chiamate premendo il tasto gancio. Prima di effettuare una chiamata in uscita bisogna sbloccare la tastiera.

## Modifica del codice segreto/password (PSWD)

Quando si accende l'apparecchio per la prima volta, la password è "0000". Si consiglia di scegliere un numero personale d'identificazione di 2-10 cifre, in modo da proteggere le programmazioni personali del vostro apparecchio portatile e i dati memorizzati ed evitare che vengano modificati da persone non autorizzate.

## Accumulatori

L'apparecchio viene fornito con due accumulatori NiMh ricaricabili, forma AA stilo.

- L'impiego di altri tipi di accumulatori o di batterie/pile non ricaricabili può essere pericoloso e inoltre causare malfunzionamenti o danni all'apparecchio.
- Controllate che gli accumulatori siano inseriti con la polarità corretta!
- Non immergete mai gli accumulatori in acqua e non gettateli nel fuoco.
- Per la base di ricarica utilizzate esclusivamente l'alimentatore a spina fornito.
- Prima della prima messa in funzione gli accumulatori devono essere ricaricati per almeno 9 ore senza interruzione.

## Avvertenze

- Durante la ricarica gli accumulatori possono scaldarsi. Si tratta di un fenomeno normale che non deve destare preoccupazione.
- Gli accumulatori raggiungono solo dopo alcuni giorni la loro piena capacità e quindi anche l'intera "durata di stand-by e conversazione".

Se l'apparecchio resta spento per parecchio tempo (p.es. durante le ferie), prima di rimetterlo in funzione bisogna ricaricare gli accumulatori.

Gli accumulatori difettosi vanno eliminati correttamente (non bisogna buttarli nei rifiuti domestici).

# Installazione e messa in servizio

## Contenuto della confezione

Nella confezione dell'apparecchio trovate:

- Base di ricarica
- Apparecchio portatile
- Clip
- 2 accumulatori
- Alimentatore a spina
- Istruzioni per l'uso

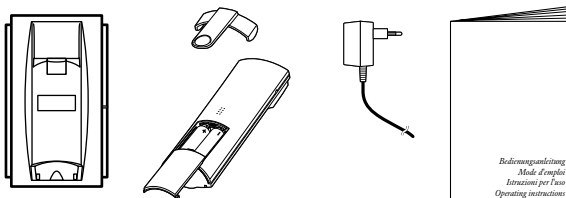

## Collegamento dell'alimentatore a spina

Collegare il cavo d'alimentazione nel connettore posto nel lato inferiore della base di ricarica e sistemare il cavo nell'apposita scanalatura.

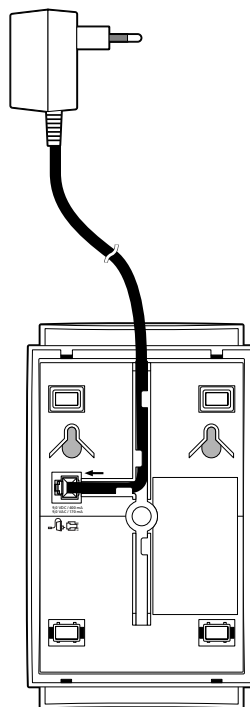

# Installazione e messa in servizio

## Da tavolo o da parete, come più vi piace

### Modello da tavolo

È il modo più semplice: non dovete che mettere l'apparecchio nel posto desiderato e collegarlo alla presa.

### Modello da parete

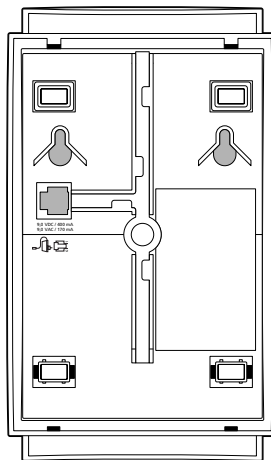
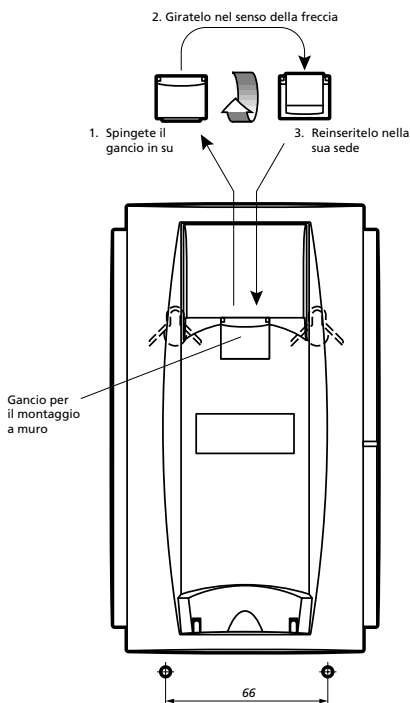

1. Girate di 180° il gancio della base di ricarica (come indicato in figura).
2. Scambiate i piedini di appoggio della base di ricarica (i piedini alti devono essere in basso), in modo che la base sia parallela alla parete.
3. Praticate due fori per i tasselli (diametro 5 mm) a una distanza di 66 mm.
4. Inserite i tasselli.
5. Avvitare le due viti, finché le teste distano circa 5 mm dalla parete.
6. Agganciate il base di ricarica alle viti e tiratela leggermente verso il basso.

# Installazione e messa in servizio

## Inserimento e caricamento degli accumulatori nell'apparecchio portatile

### Inserimento degli accumulatori

1. Togliete il coperchio del vano degli accumulatori dell'apparecchio portatile, spingendolo verso il basso, mentre simultaneamente lo tenete premuto contro l'apparecchio.
2. Inserite nel vano 2 accumulatori (come indicato in figura). Controllate che la polarità degli accumulatori sia corretta: è indicata anche all'interno del vano.
3. Fate scorrere il coperchio del vano e chiudetelo. Il coperchio si chiude con uno scatto ben udibile.

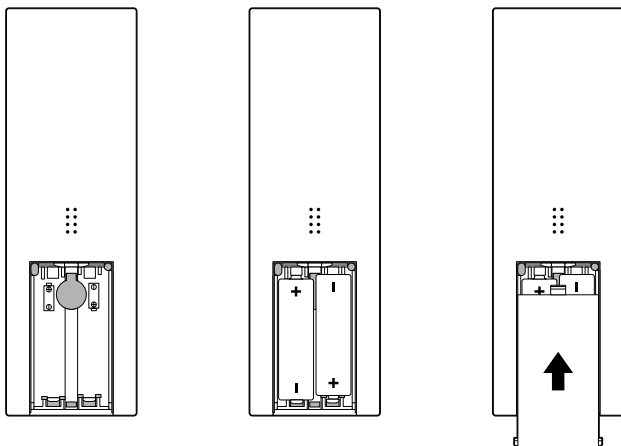

### Ricarica degli accumulatori

Al momento della consegna gli accumulatori sono scarichi. Per ricaricarli bisogna mettere l'apparecchio nella sua base di ricarica.

La spia luminosa (diodo verde) della base di ricarica

- lampeggia = gli accumulatori si stanno ricaricando
- resta acceso con luce continua = gli accumulatori sono carichi

Una carica degli accumulatori

(1100 mAh-NiMh) è sufficiente per: circa 60 ore in "Stand-by" o  
circa 8 ore in conversazione

Il tempo di ricarica è di: circa 9 ore

### Avvertenza

Con "Long Click 6" è possibile visualizzare il tipo degli accumulatori e lo stato di carica delle stesse. Dopo la sostituzione delle batterie bisogna attendere almeno 10-15 minuti di carica affinché l'indicazione dello stato di carica sia affidabile.

# Prima di telefonare la prima volta

## Impostazione della lingua del display

Normalmente la lingua del display impostata è quella della zona in cui è stato venduto l'apparecchio. Se preferite un'altra lingua, potete scegliere un'altra di quelle memorizzate nell'apparecchio.



Nel modo di programmazione, premete ripetutamente il tasto M, finché non appare "\*Lingua". (Potete vedere il carattere "\*" anche se l'indicazione è in una lingua straniera).

Con il tasto Fox sotto a "Lingua" richiamate la lingua attuale. Premete il tasto Fox sotto a "❖", finché non appare la lingua desiderata.

Confermate la lingua scelta con il tasto Fox sotto a "Ok". Con il tasto C/End ritornare allo stato di riposo.

## Impostazione del sistema PBX

Potete registrare il vostro apparecchio cordless in 4 differenti sistemi PBX (A, B, C, D). In tal modo siete raggiungibili con il vostro apparecchio anche se vi trovate in una sede della vostra ditta.



Nel modo di programmazione, premete ripetutamente il tasto M, finché non appare "Sistema". Premete il tasto Fox sotto a "Sistema". Nel display viene visualizzato "Auto" o il sistema attuale (A, B, C o D).

Premete il tasto M. Se per esempio appare l'indicazione "Registr: A" e "Cancellare", significa che l'apparecchio è stato registrato nel PBX "A" (premendo il tasto Fox sotto a "Cancellare" si potrebbe cancellare la registrazione).

Con il tasto Fox sotto a "❖" l'apparecchio può essere registrato in altri tre sistemi PBX (B, C o D). In tal caso il display indica "Registr: B (C o D)" e "Nuovo". Con il tasto Fox sotto a "Nuovo" e "Home" l'apparecchio cordless viene registrato nel sistema "B" (sempre che sia disponibile e autorizzato).

## Prima di telefonare la prima volta

Nuovo



GAP



Ok



Con un "Authentication Code" l'apparecchio può essere registrato anche in un sistema PBX estraneo con GAP (Generic Access Profile). Premete i tasti Fox sotto a "Nuovo" e "GAP", quindi dopo "AC: \_\_\_\_" introducete il codice richiesto e confermate con il tasto Fox sotto a "Ok".

### Log on per GAP, compatibilità con altri prodotti DECT

Ascotel DECT supporta tutte le caratteristiche di prestazione della telefonia di base definite nello Standard del Generic Access Profile (GAP) (edizione di fine 1997). Qui rientrano l'attivazione e la disattivazione di comunicazioni in uscita e in entrata, consultazione, selezione della frequenza (DTMF) e le procedure \*/#-. Questo significa quanto segue:

- Il vostro apparecchio terminale DECT può collegarsi ed essere utilizzato nei PBX di altri costruttori. Il presupposto per l'impiego di tutte le caratteristiche di base definite nello standard GAP è che queste siano interamente implementate nel PBX corrispondente.
- Gli apparecchi portatili DECT di altri costruttori, che soddisfano lo standard GAP, possono a loro volta collegarsi ed essere utilizzati nel vostro impianto. Essi però offrono solo la funzionalità limitata dallo standard GAP e non danno la stessa qualità del collegamento radio. In particolare, il SW per il Mobility Management con Handover/Roaming dipende quasi al 100% dagli apparecchi portatili utilizzati e non può essere adattato in maniera ottimale al vostro impianto.

### Cambio del sistema PBX



System



Nel modo di programmazione, premete ripetutamente il tasto M, finché non appare "Sistema". Premete il tasto Fox sotto a "Sistema". Nel display viene visualizzato "Auto" o il sistema attuale (A, B, C o D).



Ok



Con il tasto Fox sotto a "❄" selezionate il sistema desiderato o "Auto" e confermate con "Ok". (Se il sistema disponibile è più di uno, con "Auto" l'apparecchio cordless stabilisce automaticamente il collegamento con il sistema che offre il collegamento radio migliore).

### Avvertenze

- Con "Long Click 1" (min. 2 secondi) l'apparecchio portatile può essere commutato sul prossimo sistema PBX disponibile (A, B, C oppure D). Se la commutazione non è posizionata su "Auto", è indispensabile effettuare la commutazione manuale del sistema PBX per far sí che il vostro portatile sia pronto per l'uso nel nuovo sistema PBX.
- Con "Long Click 2" vengono visualizzate la International Portable Equipment Identity IPEI) e la PARK (Portable Access Right Key).
- Con "Long Click 5" viene visualizzato il numero della versione software dell'apparecchio portatile insieme con la data.

# Come telefonare

## Rispondere alle chiamate

L'apparecchio segnala una chiamata.



Se l'apparecchio non è nella sua base di ricarica, per rispondere alla chiamata dovete premere il tasto gancio

oppure

se l'apparecchio si trova nella sua base di ricarica, risponde non appena viene sollevato (si veda "Come programmare il vostro apparecchio", "Risposta diretta").

## Risposta per assente

Premete ripetutamente il tasto M finché compare la funzione "R.x.ass" (Risposta per assente). Premete in tale posizione il tasto Fox, sul display compare la scelta tra "Ute" (Utente), "Ricer.p." (Ricerca persone) e "SC" (Suoneria centrale). Per rispondere alla chiamata scegliere la funzione desiderata, componete il numero desiderato e premete il tasto Fox sotto "Ok".

## Durante la conversazione

Durante la conversazione il tasto M vi permette di eseguire altre funzioni, come p.es. fare una richiamata, spegnere il microfono ("Mic mute"), regolare il volume dell'auricolare da "Basso" ad "Alto" (o viceversa).



Per eseguire le altre funzioni, premete una o più volte il tasto M.

## Per terminare la conversazione

La conversazione viene interrotta premendo il tasto gancio o rimettendo l'apparecchio nella sua base di ricarica. Ovviamente la conversazione può essere interrotta anche dall'altro interlocutore. Dopo qualche secondo l'apparecchio ritorna nello stato di riposo.

## Regolazione del volume dell'auricolare durante una conversazione

Se non riuscite a sentire bene il vostro interlocutore, perché il rumore circostante è troppo forte, potete regolare il volume su "Alto".



Basso



Alto



Premete ripetutamente il tasto M finché non appare l'indicazione "Alto". Premete il tasto Fox sotto ad "Alto".

## Avvertenza

La regolazione impostata rimane anche dopo la fine della conversazione.

# Come telefonare

## Preparazione della selezione

La preparazione della selezione consente di ridurre il rischio di comporre un numero sbagliato.

Componete il numero desiderato senza premere prima il tasto gancio. Controllate il numero ed eventualmente correggetelo con il tasto C. A questo punto premete il tasto gancio: il numero desiderato viene chiamato.

## Selezione numerica

Corrisponde all'usuale procedura di selezione, però il collegamento viene stabilito solo nel momento in cui si preme il tasto gancio.



Introducete il numero desiderato e premete il tasto gancio.

## Ripetizione della selezione

Nella memoria di ripetizione della selezione restano registrati i nomi ed eventualmente i numeri degli ultimi 10 utenti chiamati.



Ripetiz.





Premete il tasto M.  
Premete il tasto Fox sotto a "Ripetizione". Viene visualizzato il numero ed eventualmente il nome dell'ultimo utente chiamato.



Premete ripetutamente il tasto Fox sotto a "❖", finché non appare il numero dell'utente desiderato.  
Premete il tasto gancio.

## Avvertenza

Il simbolo  indica che ci sono informazioni supplementari. Possono essere richiamate con il tasto .

## Selezione con l'Hotkey

L'Hotkey consente di memorizzare fino a 6 nomi/numeri di utenti a cui dovete telefonare spesso.



Premete ripetutamente l'Hotkey, finché non viene visualizzato il nome desiderato.

Meier



Premete il tasto Fox sotto al nome desiderato e poi premete il tasto gancio.

# Come telefonare

## Selezione con i nomi di un'agenda

Ci sono fino a tre elenchi (agende); un elenco interno (con tutti gli utenti derivati dal PBX), un elenco di numeri di selezione abbreviata e un'agenda privata. I nomi degli utenti consentono di realizzare il collegamento desiderato senza bisogno di introdurre il numero.

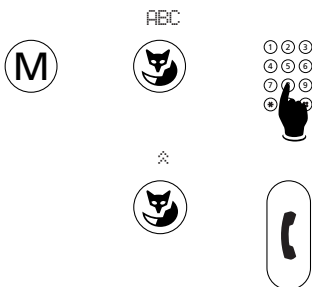

Premete il tasto M. Premete il tasto Fox sotto ad ABC; appare il menu per la scelta dell'agenda. ("Tutti" cerca in tutte le agende). Immettere le iniziali di cognomi e nomi, - ad es. E # A per Einstein Albert.

Fate scorrere l'elenco con il tasto Fox sotto a "\*" e premete il tasto gancio per avviare la selezione.

## Avvertenza

L'immissione delle iniziali è il modo più semplice per selezionare un numero memorizzato in una rubrica; in questo modo non occorre più ricordarsi il numero di telefono né il numero abbreviato dell'utente desiderato.

Esempio:

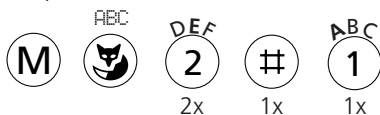

Einstein Albert:  
tasto 2: due volte  
tasto #: una volta (crea uno spazio vuoto)  
tasto 1: una volta

Se si conosce solo il cognome:



I numeri o i nomi introdotti durante la preparazione della selezione possono essere corretti con il tasto di correzione (che cancella l'ultima cifra ogni volta che lo si preme).



Un "Long Click" del tasto C pone fine ad una procedura di selezione già avviata.

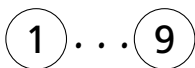

Naturalmente il vostro apparecchio portatile vi consente di effettuare la selezione anche nel modo usuale: premete il tasto gancio e selezionate il numero.





Se fra l'introduzione di due cifre aspettate più di 10 secondi la selezione viene interrotta automaticamente.

# Come telefonare

## Lista chiamate



Il vostro apparecchio memorizza automaticamente i numeri delle ultime 10 chiamate a cui non avete risposto.

Il simbolo **i** nel display vi segnala che ci sono state delle chiamate a cui non avete risposto. Potete visualizzare i numeri e chiamare i rispettivi utenti.

			Premete ripetutamente il tasto <b>i</b> , finché non appare "Chiamate". Premete il tasto Fox sotto "Chiamate" e fat scorrere la lista con il tasto Fox sotto a "❖" fino ai numeri desiderati.
			Premete il tasto gancio, per chiamare il numero visualizzato nel display. Premete il tasto Fox sotto a "Cancellare" per eliminare la registrazione dalla lista delle chiamate.



## Disattivazione del microfono

Durante una conversazione al telefono desiderate scambiare qualche parola con un'altra persona che si trova nel vostro ufficio. Il vostro apparecchio vi permette di spegnere il microfono.

	Micro	Premete il tasto Fox sotto a "Microfono". Il microfono è disattivato (nel display appare il simbolo "⊗").
	Micro	Per riaccendere il microfono premete di nuovo il tasto Fox sotto a "Microfono".

## Attivazione della chiamata discreta

Durante una riunione la suoneria dell'apparecchio può disturbare. Attivando la chiamata discreta, le chiamate in arrivo vengono segnalate acusticamente solo una volta. Voi avete la possibilità di identificare il chiamante in base a quanto indicato sul display e decidere se rispondere o meno. Se non rispondete, il chiamante viene registrato nella lista delle chiamate. Più tardi il simbolo **i** nel display ve lo ricorderà. La chiamata discreta resta attiva finché non viene disattivata. Il simbolo **i** nel display vi ricorda anche questo.

		Premete ripetutamente il tasto <b>M</b> finché non appare "Discreta". Premete il tasto Fox sotto "Discreta".
---	---	--

## Avvertenza

La chiamata discreta può essere attivata anche durante una chiamata. Ad ogni chiamata sul display appare il punto del menu "Chiamata discreta". La suoneria viene disattivata non appena si preme il tasto Fox sotto "Discreta".

# Per usare le funzioni comfort

## Disattivazione della chiamata discreta



Disattivare



Premete ripetutamente il tasto **i**, finché nel display non appare "Discreta" e "Disattivare".

Premete il tasto Fox sotto "Disattivare". La chiamata discreta è disattivata.

## "Parcheggio" di una conversazione

Durante una conversazione, un terzo utente può "bussare" da voi, ossia trasmettere un segnale di avviso. Se voi rispondete alla chiamata, la precedente viene messa in attesa. Prima di poter trasferire la seconda chiamata a un altro utente, dovete "parcheggiare" la prima.

2.\_conv



P



Premete il tasto Fox sotto a "2.\_conversazione", in modo da ripristinare la conversazione con il primo interlocutore. Premete ripetutamente il tasto **M**, finché non viene visualizzato "P" (Parcheggiare). Premete il tasto Fox sotto a "P", per parcheggiare la conversazione in atto.

2.\_conv



Premete il tasto Fox sotto a "2.\_conversazione" per passare al secondo interlocutore. A questo punto potete trasferire la chiamata a un altro utente.

Riprendere



Premete il tasto Fox sotto a "Riprendere" per ripristinare la conversazione con l'interlocutore in attesa.

## Avvertenza

A differenza di una chiamata in mantenimento, che occupa entrambi i canali vocali disponibili, il parcheggio non occupa nessun canale, il che vi consente (se necessario) di passare a un altro utente il vostro secondo chiamante. Se appare il Simbolo [P] il parcheggio è già occupato.

## Richiamata alternata

Dopo aver eseguito una richiamata, potete ritornare al primo interlocutore senza interrompere la connessione col secondo. In altre parole potete passare continuamente da un interlocutore all'altro (richiamata alternata).

2.\_conv



Premete il tasto Fox sotto a "2.\_conversazione" per passare al primo interlocutore.

2.\_conv



Premete il tasto Fox sotto a "2.\_conversazione" per ripristinare la conversazione con l'interlocutore della richiamata e così via (tutte le volte che lo desiderate o è necessario).

# Per usare le funzioni comfort

## Trasferimento della conversazione

Dopo aver realizzato una richiamata potete collegare insieme direttamente i vostri due interlocutori.



Premete il tasto gancio. Il vostro apparecchio torna automaticamente allo stato di riposo.

## Conferenza

Avete avviato una richiamata e adesso volete realizzare una conferenza telefonica (a tre) insieme con il vostro primo interlocutore.



Premete il tasto M e poi il tasto Fox sotto a "Conferenza".

## Avvertenza

Niente paura! Realizzando una conferenza non si può "perdere" nessuna chiamata. Le chiamate vengono interrotte soltanto premendo il tasto C o il tasto gancio!

## Deviazione di chiamata

Potete deviare le chiamate su un altro apparecchio, anche su quello dell'operatore oppure lasciare un messaggio.



Premete il tasto M finché non appare "Deviazione" e poi premete il tasto Fox sotto a "Deviazione".

Premete il tasto Fox sotto "☆" per selezionare il tipo di deviazione (es: "se occupato" o "a tempo")



Scegliete la destinazione della deviazione e se necessario introducete il nuovo numero. Confermate con "Ok".

## Avvertenza

Se la deviazione deve essere effettuata quando il vostro telefono è occupato, scegliere "Dev. su occ.". .

## Twin Mode (presente/assente)

Se oltre all'apparecchio cordless avete anche un telefono a filo, il twin mode vi permette di essere sempre raggiungibili. In tal caso con il Twin Mode la vostra reperibilità sarà garantita nel modo più semplice possibile. In caso di Twin Mode programmato (fare riferimento a "Come programmare l'apparecchio") viene attivata automaticamente la deviazione di chiamata, non appena sollevate l'apparecchio portatile dalla base di carica.

# Per usare le funzioni comfort

## Lasciare un'informazione in caso d'assenza

Volete lasciare un'informazione ad eventuali interlocutori interni che chiamano.



Premete ripetutamente il tasto M finché non appare "Deviare". Successivamente premete il tasto Fox sotto a "Deviare" e poi "❖", finché nel display non appare "Dev. su Info" (Deviare su informazione).



Premete il tasto Fox sotto a "Ok". Premete ripetutamente il tasto Fox sotto a "❖", finché non viene visualizzata l'informazione desiderata (simbolo **i** nel display).



Premete il tasto **i** una o più volte per visualizzare l'intera informazione.



Con il tasto C e il tastierino potete modificare l'informazione (se necessario, vedi "Selezione con i nomi"). Premete il tasto Fox sotto a "Ok".

## Avvertenza

Con il tasto C potete anche cancellare completamente il messaggio standard e scrivere un testo a piacere.

## Risposta alla prenotazione (come richiamare un utente a cui non avete risposto)

Un utente deve comunicarvi qualcosa di importante. Malgrado il vostro apparecchio portatile, non ha potuto raggiungervi. Dal suo apparecchio esegue una prenotazione.

Nel display del vostro apparecchio appare l'indicazione "Prenot. da" e "Chiam." "Cancel".



Premete il tasto Fox sotto a "Chiamare" per richiamare il chiamante oppure sotto a "Cancellare" se non è più necessario o non ha più senso richiamare.

## Ricerca dell'interlocutore mediante l'impianto ricerca-persone

Se volete cercare un utente assente mediante il ricerca persone.



Premete ripetutamente il tasto M finché compare la funzione "Ricerca persone". Premete a questo punto il tasto Fox e componete il numero dell'interlocutore cercato.



Confermare con "Ok".

# Per usare le funzioni comfort

## Prenotazione

Volete che un utente occupato o che non risponde vi richiami.



Premete il tasto Fox sotto a "Prenotazione". Sentite il suono di conferma. Nel display appare "Chiamata attesa dal Numero nnn" e "Disattivare".

Cancelare



Premendo il tasto Fox sotto "Cancellare" si annulla la prenotazione.

## Avvertenza

Si può effettuare una sola prenotazione per volta.

## Invio di un messaggio

Nel PBX sono memorizzati dei messaggi standard. Potete sceglierne uno, eventualmente completarlo o modificarlo e trasmetterlo all'utente o al gruppo desiderato.



Mess.



Premete ripetutamente il tasto M finché non appare "Messaggio". Premete il tasto Fox sotto a "Messaggio". Premete ripetutamente il tasto Fox sotto a "☆", finché non viene visualizzato il messaggio desiderato (simbolo *i* nel display).



Premete il tasto *i* una o più volte, per visualizzare il resto del messaggio.



Con il tasto C ed il tastierino potete modificare il messaggio (se necessario, vedi "Selezione con i nomi"). Premete il tasto Fox sotto a "Ok".



Selezionate il numero dell'utente/gruppo a cui è destinato il messaggio. Premete il tasto Fox sotto a "Ok" per trasmettere il messaggio.

## Avvertenze

- La procedura può essere avviata anche con la "Preparazione della selezione", ovvero si introduce prima il numero e poi si sceglie il messaggio.
- Naturalmente con il tasto C potete anche cancellare completamente il messaggio standard e scrivere un vostro messaggio personale.

# Per usare le funzioni comfort

## Letture dei messaggi

Se avete ricevuto un messaggio, nel display appare "Messaggio", insieme con il numero del mittente e le opzioni "Leggere" e "Cancellare".

Legg.



Premete il tasto Fox sotto a "Leggere". Il segno "+" indica che una parola è stata spezzata e viene visualizzata nella riga successiva.



Premete il tasto **i**, per visualizzare la riga successiva.

Alla fine del messaggio il display ritorna alle opzioni iniziali "Leggere" e "Cancellare".

Cancel



Premete il tasto Fox sotto a "Cancellare".

## Avvertenza

Per visualizzare eventuali altri messaggi, bisogna cancellare il messaggio letto.

## Annuncio

Dal vostro apparecchio portatile potete fare annunci a uno o più utenti interni, a condizione che i loro apparecchi siano muniti di altoparlante.



Annunc.



Premete ripetutamente il tasto M finché non appare "Annuncio". Premete il tasto Fox sotto ad "Annuncio".



GRUPPO



Introducete il numero dell'utente desiderato (oppure premete il tasto Fox sotto a "Gruppo" e introducete il numero del gruppo; questo per gli annunci ai gruppi di utenti predefiniti).

Ok



Premete il tasto Fox sotto a "Ok" e fate l'annuncio.

# Per usare le funzioni comfort

## Modo trasparente (selezione in multifrequenza DTMF)

Durante un collegamento la selezione in multifrequenza consente di attivare una determinata funzione, p.es. di ascoltare i messaggi della segreteria telefonica.



"Long Click" del tasto \* fino a quando viene visualizzato il messaggio "Trasparente".  
Introducete la sequenza di caratteri per attivare la funzione desiderata.

Terminata l'operazione:



Premete il tasto C per disattivare il modo trasparente

oppure

Disattivare premete il tasto Fox sotto ad "Disattivare".



## Attivazione/conclusione di una richiamata

Durante una conversazione il vostro interlocutore vi pone una domanda a cui non siete in grado di rispondere. Desiderate consultare un altro collaboratore, senza interrompere la connessione.



Richiama



Introducete il numero dell'utente che volete consultare.  
Premete il tasto Fox sotto a "Richiamata";  
l'utente viene chiamato (la conversazione precedente viene posta in attesa).

Dopo aver ricevuto l'informazione desiderata:



Premete il tasto C per ritornare alla conversazione con il primo interlocutore.

## Avvertenza

Se dopo una richiamata si preme il tasto gancio, per 10 secondi viene emesso un segnale acustico continuo. Per ripristinare il collegamento con l'interlocutore in attesa, premete il tasto gancio.





# Come programmare il vostro apparecchio

## Cosa occorre osservare nella programmazione

La programmazione fa parte del metodo di comando; prima di iniziare la programmazione, leggete il capitolo "Metodo di comando" all'inizio delle presenti istruzioni.

## Modo di programmazione

Potete attivare il modo di programmazione in due modi:

 "Long click" (min. 2 secondi) del tasto menu  
oppure  
 ...    **Programmare**  
premete ripetutamente il tasto M finché non viene visualizzato "Programmare".

## Avvertenza

I "Long Click" dipendono dal software e dal tipo di PBX.

## Tasto menu

Il tasto M vi permette di muovervi a due livelli: dapprima nei menu di programmazione (PRG 1-...; selezionate il settore che desiderate programmare, p.es. "Tasti") e successivamente a livello delle sottofunzioni (p.es. occupazione di un tasto numerico). Da entrambi i livelli potete uscire premendo il tasto C/End o il tasto gancio.

## Memorizzazione

I dati da voi introdotti o modificati nel punto di un menu vengono memorizzati quando premete il tasto Fox sotto a "Ok". Se invece premete un altro tasto, la programmazione che avete effettuato non viene memorizzata.

# Come programmare il vostro apparecchio

## Vista d'Insieme

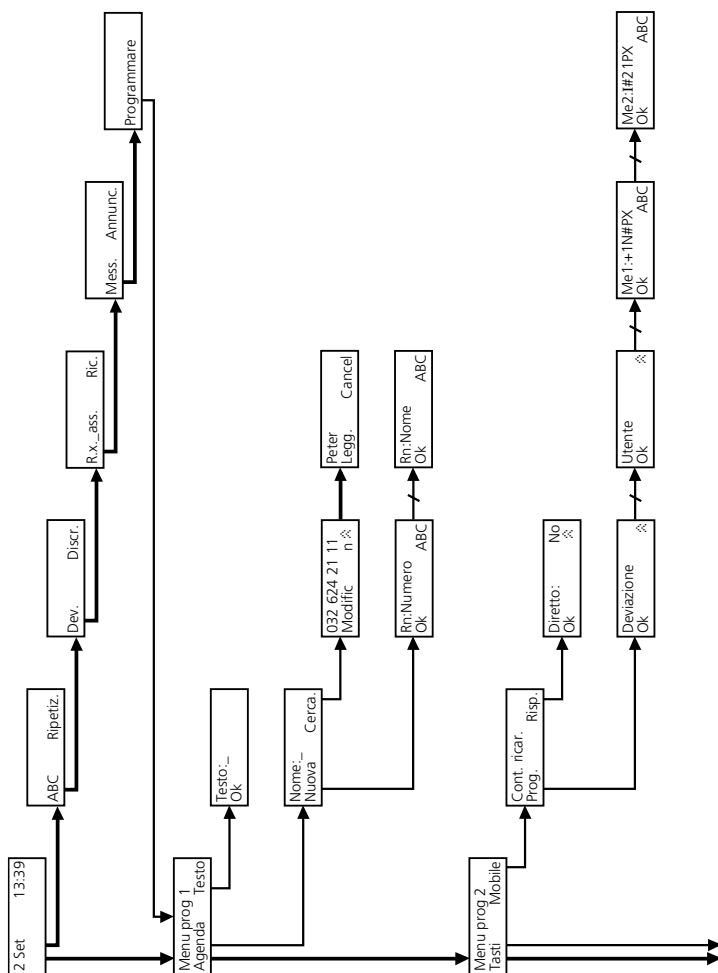



# Come programmare il vostro apparecchio

## Vista d'Insieme

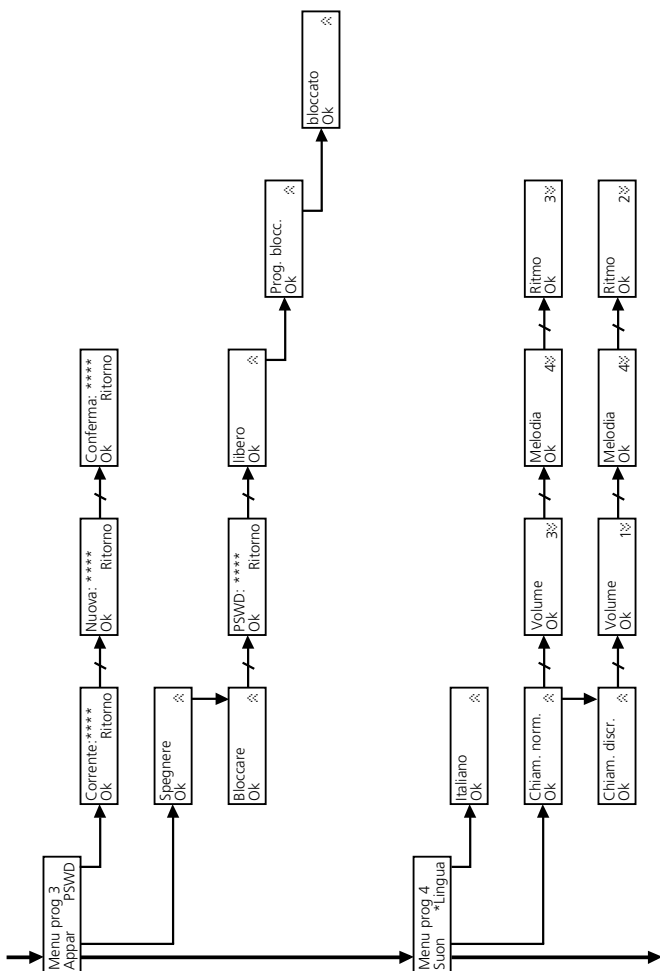

# Come programmare il vostro apparecchio

## Vista d'Insieme

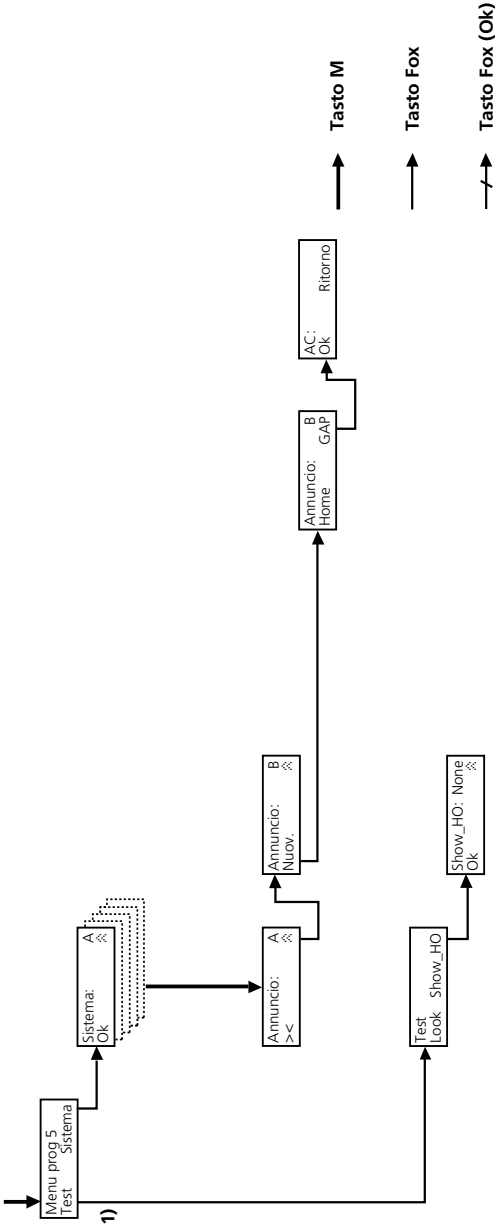

1) Il punto del menu "Test" è riservato all'installatore

# Come programmare il vostro apparecchio

## Twin Mode (presente/assente)

Se oltre all'apparecchio cordless avete anche un telefono a filo, il twin mode vi permette di essere sempre raggiungibili.

Il contatto della base di ricarica riconosce 2 stati:

- a) apparecchio nella base di ricarica (presente)
- b) apparecchio fuori della base di ricarica (assente)

In base a tali due stati viene eseguita la deviazione automatica della chiamata (DDC) sull'apparecchio cordless non appena viene tolto dalla base di ricarica.

Quando si rimette l'apparecchio nella base di ricarica la deviazione viene disinserita automaticamente.

## Attivazione del Twin Mode



Mobile

Nel modo programmazione premere il tasto M tante volte fino a far apparire la dicitura "Mobile". Premere il tasto Fox sotto "Mobile".



Prog.



Prog.



Ok

Premere il tasto Fox sotto "Prog.", quindi effettuare lo scroll tra "☼" e "Twin" con il tasto Fox e confermare con "Ok".



Ok

Alla voce "TwinN.:" immettere il numero di allacciamento dell'apparecchio fisso che deve essere deviato sull'apparecchio portatile. Attivare il Twin Mode con il tasto Fox sotto "Ok".

## Disattivazione del Twin Mode



Mobile

Nel modo programmazione premere il tasto M tante volte fino a far apparire la dicitura "Mobile". Premere il tasto Fox sotto "Mobile".



Prog.



Prog.



Ok

Premere il tasto Fox sotto "Prog.", quindi effettuare lo scroll tra "☼" e "Nessuna funzione" e disattivare il Twin Mode con il tasto Fox sotto "Ok".

## Avvertenze

- Se su un apparecchio terminale fisso viene attivata una AUL/RWS verso la segreteria, la Voice Mail o verso il proprio apparecchio GSM etc., mentre il portatile si trova nella base di ricarica, in questo caso questa funzione ha una priorità maggiore rispetto al Twin Mode. Non viene effettuata alcuna deviazione automatica al portatile se lo stesso viene preso dalla base di ricarica. Il Twin Mode viene nuovamente attivato, non appena viene disattivata la AUL/RWS impostata nell'apparecchio fisso.
- Oltre al Twin Mode è possibile impostare anche altre funzioni (fare riferimento al manuale di programmazione "Mobile")

# Come programmare il vostro apparecchio

## Agenda privata

Oltre all'elenco degli utenti del PBX e all'elenco di selezione abbreviata, potete preparare un'agenda privata con un massimo di 30 (00..29) numeri telefonici e nomi. Bloccando le funzioni di programmazione del vostro apparecchio portatile, potete evitare che tali dati vengano modificati da persone non autorizzate.



Nel modo di programmazione premete ripetutamente il tasto M, finché non appare "Agenda".

Agenda



Premete il tasto Fox sotto ad "Agenda" e quindi sotto a "Nuova" o "Cerca".

Nuova



Premendo "Nuova" viene visualizzata la prima memoria libera.

Introducete numero e confermate con "Ok", nome e memorizzate con "Ok".

Cerca



Dopo aver premuto "Cercare", fate scorrere l'agenda con il tasto Fox sotto a "☼", finché non appare la registrazione desiderata.

Modific



Premete il tasto Fox sotto a "Modificare", modificate le registrazioni e memorizzatele premendo il tasto Fox sotto a "Ok".

## Avvertenze

- Se una memoria è già stata programmata, viene visualizzata la registrazione corrente. Ovviamente potete modificare i dati registrati.
- È consigliabile introdurre per ogni numero il nome corrispondente; ciò facilita notevolmente la ricerca e la selezione alfabetica.
- Quando durante una chiamata viene visualizzato il numero del chiamante sul display (CLIP), il sistema cerca tale numero negli elenchi e nell'agenda privata. Se è stato memorizzato già con un nome, viene visualizzato anche il nome.

# Come programmare il vostro apparecchio

## Linguaggio macro

Il linguaggio macro consente di memorizzare sotto un solo tasto diverse funzioni una dopo l'altra.

I	Impegnare
X	Realizzare la connessione
P	Pausa (1 secondo)
N	Inserire il numero introdotto nella preparazione della selezione
.	Funzione tasto di registro
Z	Attivare/disattivare modo trasparente
R	Inserire l'ultimo numero selezionato

Esempi:

I201 Impegnare e chiamare il 201

I\*21201X Impegnare, eseguire la deviazione delle chiamate sul 201 e chiamare quest'ultimo.

## Programmazione del testo per lo stato di riposo

Al posto di data e/o ora per lo stato di riposo del vostro apparecchio potete definire un testo personale.

Testo



Nel modo di programmazione premete il tasto Fox sotto a "Testo" e introducete il testo desiderato (al massimo 12 caratteri).

Ok



Premete il tasto Fox sotto a "Ok" per memorizzare il testo introdotto.

End



Modificate il testo per lo stato di riposo (se necessario).

Con il tasto di correzione (C/End) si possono cancellare i caratteri a sinistra del cursore.

Ok



Terminata l'editazione del testo, premete il tasto Fox sotto a "Ok".

## Avvertenza

Un "Long Click" del tasto C/End (min. 2 secondi) consente di ritornare al menu precedente.

# Come programmare il vostro apparecchio

## Blocco/sblocco della tastiera

Potete bloccare la tastiera per evitare che i tasti vengano premuti inavvertitamente. Le chiamate vengono segnalate comunque e voi potete rispondere premendo il tasto gancio. Dopo la conversazione è possibile effettuare una chiamata in uscita entro 5 secondi. Trascorsi i 5 secondi il bloccaggio dei tasti viene immediatamente riattivato (variante 1).



Tasti



Ok



Sbloccare



Si



Nel modo di programmazione premete ripetutamente il tasto M finché non appare "Tasti".

Premete il tasto Fox sotto a "Tasti". Il display indica "Blocco tasti".

Bloccate la tastiera premendo il tasto Fox sotto ad "Ok".

Il display indica "Sbloccare".

Premete il tasto Fox sotto a "Sbloccare". L'apparecchio chiede una conferma con "Sbloccare?", per sapere se il blocco della tastiera deve veramente essere tolto.

Con "Si" appare il "Display di riposo" e l'apparecchio funziona di nuovo normalmente.

## Avvertenze









- Con "Long Click 8" (min. 2 secondi) è possibile attivare anche la variante 1 del bloccaggio tasti.
- Con "Long Click 9" è possibile attivare la variante 2 del bloccaggio tasti. In caso di chiamata questa funzione non viene disabilitata automaticamente, ma deve avvenire manualmente (fare riferimento a quanto scritto in precedenza), per poter rispondere alla telefonata con il tasto di conversazione.

# Come programmare il vostro apparecchio

## Programmazione dell'Hotkey

L'Hotkey è un tasto liberamente programmabile, che permette di memorizzare fino a 6 numeri/nomi o funzioni. Con le macro potete memorizzare intere procedure.

## Memorizzazione di numeri/nomi sotto all'Hotkey

-   **Tasti** Nel modo di programmazione premete il tasto M finché non appare "Tasti". Premete il tasto Fox sotto a "Tasti".
-   **Ok** Premete il tasto Fox sotto "❖", finché compare "Hotkey". Premendo il tasto Fox sotto "Ok" compaiono le scritte "Hotkey Prg:" (Hotkey programmazione), "Hk1" e "Hk2".
-   **Ok** Premendo una/due volte il tasto M, richiamate le memorie "Hk3" e "Hk4", rispettivamente "Hk5" e "Hk6".  
Selezionate con il tasto Fox le memorie desiderate (Hk1...Hk6).
-  **Ok** Nel menu "Nn: Numero" confermate ancora con "Ok".
-   **Ok** Introducete numeri e confermate con "Ok", nome e premete il tasto Fox sotto a "Ok" per memorizzare la registrazione.

## Avvertenza

Con un "Long click" sul tasto Hotkey si entra direttamente nel menu di programmazione.

# Come programmare il vostro apparecchio

## Memorizzazione di una funzione sotto all'Hotkey

Si procede come sotto a numeri/nomi, fino alla selezione delle memorie Hk1...Hk6, quindi:



Premete il tasto Fox sotto a "\*" per richiamare il menu "Fn: Funzione", quindi confermate con "Ok".



Premete ripetutamente il tasto sotto a "\*", finché non viene visualizzata la funzione desiderata, poi confermate con "Ok".



Viene visualizzato il contenuto della memoria 1 (Me1) per questa funzione (attivare la funzione). Premete il tasto Fox sotto a "Ok" per memorizzare la funzione.



Se desiderato introducete il nome e confermate con "Ok". Il contenuto della memoria 1 (Me1) viene memorizzato, simultaneamente viene visualizzato il contenuto della memoria 2 (Me2) (disattivare la funzione).



Con "Ok" la funzione viene memorizzata.

## Avvertenze







- Nelle due memorie vengono registrati automaticamente i corrispondenti codici di funzione. Se necessario tali codici possono essere completati/modificati.
- Se durante la procedura di memorizzazione non viene immesso alcun nome, il sistema introduce un breve nome predefinito.
- Se una delle funzioni programmate è attiva, nella riga dei simboli appare "■" e la funzione corrispondente viene marcata con "⌘".
- Un "Long click" sul tasto Hotkey fa saltare direttamente al menu di programmazione.

# Come programmare il vostro apparecchio

## Programmazione del tasto Fox

Potete utilizzare entrambi i tasti Fox come tasti programmabili liberamente. In tal modo allo stato di riposo il vostro display indica poi i numeri utilizzati più spesso o le funzioni che potete attivare comodamente premendo un unico tasto (la volpe corrispondente). Se sotto al tasto Fox viene memorizzata una funzione, il suo stato attivo viene visualizzato con il simbolo "¶".

## Memorizzazione di numeri/nomi o funzioni sotto al tasto Fox







	<b>Tasti</b> 	Nel modo di programmazione premete ripetutamente il tasto M, finché non appare "Tasti". Premete il tasto Fox sotto a "Tasti".
		Premete ripetutamente il tasto Fox sotto a "¶", finché non appare "Tasto_Fox".
	<b>Ok</b> 	Premete il tasto Fox sotto a "Ok" e quindi scegliete il tasto desiderato ("Fox1" o "Fox2").
<b>Fox1</b> 	<b>Fox2</b> 	Continuate come con "Programmazione dell'Hotkey".

## Avvertenze

- Un "Long click" del tasto Fox consente di passare direttamente alla programmazione dei tasti Fox.
- Se entrambi i tasti Fox sono occupati da un numero o una funzione e un nome, si perde la visualizzazione della qualità.
- La visualizzazione della qualità viene invece conservata quando per il tasto Fox 1 o 2 al posto di un nome viene immesso uno spazio con il tasto #.

## Segnale acustico di conferma dei tasti

Se lo si desidera, l'apparecchio portatile può confermare con un breve segnale acustico l'azionamento di ogni tasto.

	<b>Tasti</b> 	Nel modo di programmazione premete ripetutamente il tasto M, finché non appare "Tasti". Premete il tasto Fox sotto a "Tasti".
	<b>Ok</b> 	Premete il tasto Fox sotto a "¶", finché non appare "Segnale di conferma". Confermate con "Ok".
	<b>Ok</b> 	Con il tasto Fox sotto a "¶" scegliete "Segnale: Si" oppure "Segnale: No". Premete il tasto Fox sotto a "Ok" per confermare programmazione.

## Avvertenza





Quando si rimette l'apparecchio portatile nella sua base di ricarica viene sempre emesso un breve segnale acustico di conferma.

# Come programmare il vostro apparecchio

## Risposta diretta (senza il tasto gancio)



Se l'apparecchio portatile è predisposto per rispondere in modo "Diretto", quando arriva una chiamata è sufficiente togliere l'apparecchio dalla base di ricarica, senza bisogno di premere il tasto gancio.

Quando si rimette l'apparecchio nella base di ricarica il collegamento viene interrotto, se non è stato precedentemente interrotto con il tasto gancio.

	Mobile 	Risp. 	Nel modo di programmazione premete ripetutamente il tasto M, finché non appare "Mobile". Premete il tasto Fox sotto a "Mobile" e poi sotto a "Rispondere".
		Ok 	Con il tasto Fox sotto a "❖" passate su "Diretto: Si". Confermate con il tasto Fox sotto a "Ok" la predisposizione "Diretto: Si".

## Accensione e spegnimento dell'apparecchio portatile



### Spegnimento

	Nel modo di programmazione premete ripetutamente il tasto M, finché non appare "Apparecchio".
Appar. 	Premete il tasto Fox sotto ad "Apparecchio"; appare "Spegnere".
Ok 	Premete il tasto Fox sotto a "Ok" per spegnere l'apparecchio. Il collegamento con l'unità radio viene interrotto (il display si spegne).

### Avvertenze

- L'apparecchio viene spento anche con un "Long click" (min. 2 secondi) del tasto 0 dei tasti numerici.
- Al di fuori della portata massima dell'unità radio l'apparecchio portatile cerca sempre di stabilire un collegamento con un'unità radio. Per non consumare inutilmente la batteria, si consiglia di spegnere l'apparecchio quando si esce per parecchio tempo dalla portata massima dell'unità radio.

### Accensione

	Si 	Premere il tasto gancio e attivare l'apparecchio con il tasto Fox alla voce "Si".
---	---	---

# Come programmare il vostro apparecchio

## Bloccare/sbloccare l'apparecchio portatile

Potete bloccare il vostro apparecchio portatile per evitare abusi. Con questa funzione viene attivato il blocco cifre del PBX. Il Gestore del vostro sistema può spiegarvi se e in caso affermativo quali numeri (p.es. i numeri di emergenza) possono essere composti e chiamati malgrado il blocco.

Quando l'apparecchio è bloccato, potete comunque rispondere immediatamente alle chiamate premendo il tasto gancio. Prima di poter effettuare una telefonata in uscita bisogna invece sbloccare l'apparecchio.

È consigliabile bloccare le funzioni di programmazione del vostro apparecchio portatile con "Prog.blo". In tal modo potete p.es. proteggere le registrazioni della vostra agenda privata.

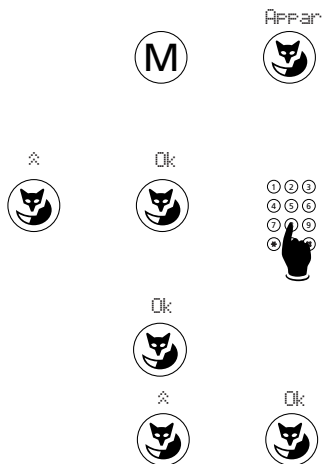

Nel modo di programmazione premete ripetutamente il tasto M, finché non compare "Apparecchio" e poi premete il tasto Fox sotto ad "Apparecchio"; viene visualizzato "Spegnere".

Con il tasto Fox sotto a "\*" selezionate "Bloccare", premete "Ok" e introduce il codice segreto/password (PSWD).

Premete il tasto Fox sotto a "Ok" e poi con il tasto Fox sotto a "\*" scegliete "libero", "Prog.\_blo" (Programmazione bloccata" o "bloccato" (con "libero" l'eventuale blocco viene disattivato).

Premete il tasto Fox sotto a "Ok".

## Modifica del codice segreto/password (PSWD)

Quando si accende l'apparecchio portatile per la prima volta il codice segreto/password ha il valore "0000". Si consiglia di scegliere subito un codice segreto di 2-10 cifre, in modo da proteggere dagli abusi (modifica, cancellazione) la programmazione personale dell'apparecchio e i dati memorizzati.

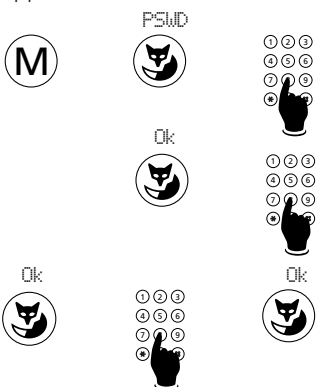

Nel modo di programmazione premete ripetutamente il tasto M, finché non appare "PSWD" (password). Premete il tasto Fox sotto a "PSWD" e introduce il codice valido al momento.

Premete il tasto Fox sotto a "Ok" e introduce la nuova password "Ok".

Premete il tasto Fox sotto a "Ok", appare "Conferma". Introduce una seconda volta la nuova password e confermate con il tasto Fox sotto a "Ok".

# Come programmare il vostro apparecchio

## Impostazione della chiamata discreta e della suoneria

Il vostro apparecchio portatile può segnalare una chiamata con diversi volumi, melodie e ritmi. Potete scegliere la versione che preferite, in modo che vi sia più facile distinguere se una determinata chiamata è per voi o se proviene dall'apparecchio del vostro vicino. In caso di "Chiamata discreta" l'apparecchio segnala ogni chiamata suonando una sola volta.



Nel modo di programmazione premete ripetutamente il tasto M, finché non appare "Suoneria".

Suon.



Premete il tasto Fox sotto a "Suoneria" e con il tasto Fox sotto a "☒" scegliete "Chiamata normale" o "Chiamata discreta".

Ok



Premete il tasto Fox sotto a "Ok", per attivare il segnale acustico impostato.

☒



Premete ripetutamente il tasto Fox sotto a "☒", fino a ottenere il volume desiderato.

Ok



Premete il tasto Fox sotto a "Ok", per memorizzare l'impostazione e selezionare una melodia nel menu successivo con il tasto Fox sotto a "☒".

Ok



☒



Ok



Dopo aver memorizzato la melodia con "Ok", nel menu "Ritmo" premete il tasto Fox sotto a "☒" per scegliere il ritmo desiderato, quindi confermate con il tasto Fox sotto a "Ok".

## Avvertenza

Con il tasto M potete passare ciclicamente fra i punti del menu "Volume", "Melodia" e "Ritmo", senza bisogno di memorizzare le eventuali modifiche eseguite.

# Malfunzionamenti

## Uscita dalla portata massima dell'unità radio

Poco prima di uscire dal campo radio viene emesso un suono di avvertimento. Dopo essere usciti dal campo viene visualizzato il messaggio "Nessun sistema" e scompare il simbolo dell'antenna "☎".

Se si esce dal campo radio nel corso di una conversazione, la stessa viene interrotta, ma il collegamento non viene subito sospeso. Il sistema cerca per 20 secondi un nuovo collegamento radio con la stessa o con un'altra unità radio. Solo dopo il collegamento viene interrotto nel PBX.

Al di fuori della portata massima dell'unità radio con il tasto M avete a disposizione le seguenti funzioni di programmazione:

"Prog.", "Tasti", "Mobile", "Appar", "Chiamata", "\*Lingua" "Test" e "Sistema".

## Il display è acceso, ma non si sente il tono continuo

Probabilmente l'apparecchio portatile è bloccato (si veda "Blocco/sblocco dell'apparecchio").

## Non si riesce a programmare l'Hotkey e/o i tasti Fox

Probabilmente la programmazione è bloccata (si veda "Blocco/sblocco dell'apparecchio").

## Volete sbloccare l'apparecchio, ma avete dimenticato il codice segreto

Pregate l'operatrice di cancellare il vostro codice segreto dal sistema.

## Indicazioni del display

### "Attendere p.f."

Questo messaggio può apparire durante la procedura di registrazione dell'apparecchio. Inoltre appare quando un interlocutore mette in attesa il collegamento.

### "Apparecchio ignoto"

L'apparecchio cordless non è riuscito a registrarsi nel PBX. Rivolgersi al Gestore del sistema.

### "Sovraccarico"

Nessuna risorsa disponibile, attendere un momento e riprovare.

### "System Busy"

Attraverso l'unità radio attuale al momento non è possibile stabilire alcun collegamento. L'apparecchio portatile cerca di stabilire un collegamento radio migliore con la stessa o con un'altra unità radio. Il messaggio viene visualizzato solo durante lo standby.

### "Nessun Sistema"

L'apparecchio è uscito dalla portata dell'unità radio; il collegamento con il sistema PBX è stato interrotto.

### "Registrare"

L'apparecchio sta registrandosi al sistema PBX.

### "Averia" / chiamata progressiva permanente

Ogni volta che l'apparecchio portatile viene posato nella base di carica i suoi parametri vengono verificati. Se viene rilevato un parametro errato il sistema emette un segnale acustico e sul display viene visualizzata la dicitura "Errato". L'apparecchio portatile deve essere rispedito al fornitore, il quale provvederà alla riparazione/sostituzione.

## Avvertenza

Per altre segnalazioni rivolgersi al Gestore del sistema.

# Codici di funzione

## Le cifre che bisogna comporre?

Selezione normale	Sequenza di tasti
L'operatore .....	11 .....
Interfoni porte .....	851... 852 <sup>1)</sup> .....
Itinerario .....	170... 199 <sup>1)</sup> .....
Numeri collegamenti collettivi .....	860... 888 <sup>1)</sup> .....
Numero di soccorso .....	12 .....
Selezione abbreviata in generale (PBX) .....	7000...7999 <sup>1)</sup> .....
<b>Uscita per linea urbana</b>	
ditta .....	0 .....
privato .....	10 .....
con centro di costo .....	13 N. C.d.C. ....

## Postselezione

<b>Attivare impianto ricerca persone</b> .....	8 o *81
<b>Attivare la chiamata codificata</b> .....	8 o *81
<b>Avvertimento/Avviso</b> .....	6 o *43
rifiuto .....	0
risposta con mantenimento .....	2
risposta senza mantenimento .....	1
risposta con conferenza .....	3
<b>Commutazione fra due collegamenti</b> .....	2
<b>Conferenza</b>	
stabilire (da un collegamento) .....	3
escludere un interlocutore (interno) .....	*31
<b>Intercalazione/Inclusione</b> .....	7 o *44
rifiuto .....	0
risposta con mantenimento .....	2
risposta senza mantenimento .....	1
<b>Parcheggiare il collegamento</b> .....	*76
<b>Prenotazione da N. / MESSAGE</b>	
attivare segnalazione .....	*38
<b>Richiamo/Prenotazione automatica</b>	
attivare se l'utente è occupato .....	9 o *37
attivare se l'utente è libero .....	9 o *37

1) La definizione e il campo di numerazione dipendono dal centralino e del Software

# Codici di funzione

Ripresa della conversazione .....	1
<b>Trasferire la conversazione in corso</b>	
su centro di costo no. ....	*78 N. C.d.C.

## Preselezione

---

<b>Annuncio/Chiamata su altoparlante</b>	
a un utente .....	*7998 N. utente
a un gruppo .....	*79 N. gruppo
rispondere a un annuncio di gruppo .....	*89
<b>Aprire porta</b> .....	*751... *752 <sup>1)</sup>
<b>Avvertimento</b> <sup>2)</sup>	
blocco .....	*04
autorizzazione .....	#04
<b>Cancellare prenotazione</b> .....	#37
<b>Chiamata codificata</b>	
attivare .....	*81 N. utente
rispondere .....	*82
<b>Chiamata scadenza termine</b> (ordine sveglia) <sup>2)</sup>	
attivare ordine permanente .....	*56 hh mm
cancellare ordine permanente .....	#56
attivare ordine singolo .....	*55 hh mm
cancellare ordine singolo .....	#55
<b>Collegamento</b>	
parcheggiare .....	*76
riprendere il collegamento parcheggiata .....	#76
<b>Collegamento collettivo</b> <sup>2)</sup>	
inserirsi .....	*48
disinserirsi .....	#48
<b>Commutazione di giorno, notte, fine settimana</b> (gr. commutaz. 1)	
giorno (posizione 1) .....	*8511
notte (posizione 2) .....	*8512
fine settimana (posizione 3) .....	*8513
<b>Conferenza</b>	
variabile .....	*71 N. ut. 1* ... N. utente 5# <sup>1)</sup>
prestabilita .....	*70 N. conf.

1) La definizione e il campo di numerazione dipendono dal centralino e del Software

2) Telecomando possibile

## Deviazione di chiamata DDC

blocco della DDC sul proprio apparecchio <sup>2)</sup> .....	*02
sblocco della DDC sul proprio apparecchio <sup>2)</sup> .....	#02
attivare DDC incondizionata <sup>2)</sup> .....	*21 N. dest.
cancellare DDC incondizionata <sup>2)</sup> .....	#21
attivare DDC incondizionata sull'ultimo numero progr. ....	*21#
cancellare DDC incondizionata sull'ultimo numero progr. .	#21
attivare DDC sul numero preprogrammato <sup>2)</sup> .....	*22
cancellare DDC sul numero preprogrammato <sup>2)</sup> .....	#22
attivare DDC se occupato <sup>2)</sup> .....	*67 N. dest.
cancellare DDC se occupato <sup>2)</sup> .....	#67
attivare DDC sull'ultimo numero programmato se occ. ....	*67#
cancellare DDC sull'ultimo numero programmato se occ. .	#67
attivare DDC su messaggio standard <sup>2)</sup> .....	*24 N. testo
cancellare DDC su messaggio standard <sup>2)</sup> .....	#24
attivare DDC sull'impianto cercapersona IRP o sulla suoneria centrale con chiamata codificata <sup>2)</sup> .....	*28
cancellare DDC sull'impianto cercapersona IRP o sulla suoneria centrale con chiamata codificata <sup>2)</sup> .....	#28

**Disattivare tutti i servizi attivati** <sup>2)</sup> ..... \*00  
(a parte il collegamento collettivo)

## Dirottamento di chiamata DCA (deviazione di chiamata in caso di mancata risposta)

blocco della DCA <sup>2)</sup> .....	*02
sblocco della DCA <sup>2)</sup> .....	#02
attivare DCA <sup>2)</sup> .....	*61 N. dest.
cancellare DCA <sup>2)</sup> .....	#61
attivare DCA sull'ultimo numero progr. ....	*61#
cancellare DCA sull'ultimo numero progr. ....	#61
attivare DCA sul numero preprogrammato <sup>2)</sup> .....	*62
cancellare DCA sul numero preprogrammato <sup>2)</sup> .....	#62
attivare DCA sull'impianto cercapersona IRP o sulla suoneria centrale con chiamata codificata <sup>2)</sup> .....	*68
cancellare DCA sull'impianto cercapersona IRP o sulla suoneria centrale con chiamata codificata <sup>2)</sup> .....	#68

## Gruppo commutazione (in entrata)

gruppo commutazione x, pos. 1 .....	*85x1
gruppo commutazione x, pos. 2 .....	*85x2
gruppo commutazione x, pos. 3 .....	*85x3

Avvertenza: x è una cifra da 2 a 9.

## Impianto ricerca persone

cercare .....	*81 N. utente
rispondere con un canale di ricerca .....	*82
rispondere con più canali di ricerca .....	*82 N. utente

## Intercalazione/Inclusione <sup>2)</sup>

blocco .....	*04
autorizzazione .....	#04

<sup>2)</sup> Telecomando possibile

# Codici di funzione

**Intercezione di chiamata/Risposta per assente** ..... \*86 N. utente

**Messaggi** (messaggi standard con/senza parametri) <sup>2)</sup>

trasmissione a un utente ..... \*3598 N. utente N. testo #  
trasmissione a un gruppo ..... \*35 N. gruppo N. testo #  
trasmissione a tutti ..... \*3599 N. testo #

**Prenotazione da N. / MESSAGE** <sup>2)</sup>

attivare segnalazione ..... \*38 N. utente  
cancellare, apparecchio destinazione ..... #38 N. utente

**Quiete telefonica** (blocco chiamate in arrivo) <sup>2)</sup>

attivare ..... \*26  
cancellare ..... #26

**Relè**

attivare ..... \*755...\*757 <sup>1)</sup>  
disattivare ..... #755...#757 <sup>1)</sup>

**Risposta alla chiam. circolare/suoneria central.** ..... \*83

**Seguimi** (Follow me)

attivare ..... \*23 N. utente  
cancellare ..... #23

**Servizio cortesia**

attivare gruppo 1 ..... \*931  
disattivare gruppo 1 ..... #931  
attivare gruppo 2 ..... \*932 <sup>1)</sup>  
disattivare gruppo 2 ..... #932 <sup>1)</sup>

**Telecomando**

**avviare** (da un apparecchio estraneo) ..... \*06 N. d'utente \*21 N. dest.

avviate il telecomando /

introducete il numero d'utente il cui

apparecchio volete usare a distanza /

introdurre la procedura \* desiderata (p.e. \*21 N. dest.)

**disattivare** (da un apparecchio estraneo) ..... \*06 N. d'utente #21

avviate il telecomando /

introducete il numero d'utente il cui

apparecchio è usato a distanza /

introdurre la procedura # desiderata (p.e. #21)

**disattivare** (dal proprio apparecchio) ..... #21

introdurre la procedura # (p.e. #21)

**Uscita per linea urbana** <sup>2)</sup>

attivare con richiamo per comunicazione addebiti ..... \*32 N. utente

1) La definizione e il campo di numerazione dipendono dal centralino e del Software

2) Telecomando possibile

## A

ABC 13  
Accensione e spegnimento dell'apparecchio portatile 33  
Accumulatori 5, 8  
Agenda privata 13, 27  
Annuncio 19  
Avvertenze di sicurezza 4, 5

## B

Bloccare/sbloccare l'apparecchio portatile 34  
Blocco/sblocco della tastiera 29

## C

Cambio del sistema PBX 10  
Chiamata discreta 14, 15, 35  
Chiamate 14  
Codice segreto 5, 34  
Conferenza 16  
Conferma dei tasti 32

## D

Deviazione di chiamata 16  
Disattivazione del microfono 14  
Discreta 14, 15, 35  
Display 1, 9  
DTMF 20

## H

Hotkey 12, 30, 31

## I

Impostazione del sistema PBX 9  
Impostazione della chiamata discreta e della suone 35  
Impostazione della lingua del display 9  
Installazione 6, 7, 8  
Invio di un messaggio 18

## L

Lasciare un'informazione in caso d'assenza 17  
Lettura dei messaggi 19  
Lingua 9  
Linguaggio macro 28  
Lista chiamate 14  
"Long Click" funzioni  
⑧ Bloccaggio tasti (variante 1) 29  
⑨ Bloccaggio tasti (variante 2) 29  
① Cambio del sistema PBX 10

Ⓜ Modifica la direzione di ricerca 3  
Ⓜ Modo di programmazione 3, 21  
ⓧ Modo trasparente 20  
④ Qualità del collegamento 2  
② Portable Equipment Identity IPEI 10  
Ⓜ Programmazione dei tasti Fox 32  
Ⓜ Programmazione dell'Hotkey 30, 31  
Ⓜ Ritornare al menu precedente 13, 28  
① Spegnimento 33  
⑥ Tipo degli accumulatori 8  
⑤ Versione software dell'apparecchio 10

## M

Malfunzionamenti 36  
Messaggio 18, 19,  
Microfono 14  
Modifica del codice segreto/password 34

## P

Parcheggio di una conversazione 15  
Password 5, 34  
Prenotazione 17, 18  
Programmazione 21  
Programmazione del tasto Fox 32  
Programmazione dell'Hotkey 30, 31

## R

Regolazione del volume dell'auricolare 11  
Ricerca persone 17  
Richiamata 20  
Richiamata alternata 15  
Ripetizione della selezione 12  
Risposta alla prenotazione 17  
Risposta diretta 33  
Risposta per assente 11

## S

Selezione 12  
Selezione con l'Hotkey 12  
Selezione in multifrequenza DTMF 20  
Spegnimento dell'apparecchio 33  
Suoneria 35

## T

Tasto Fox 32  
Testo per lo stato di riposo 28  
Trasferimento della conversazione 16  
Twin Mode 16, 26

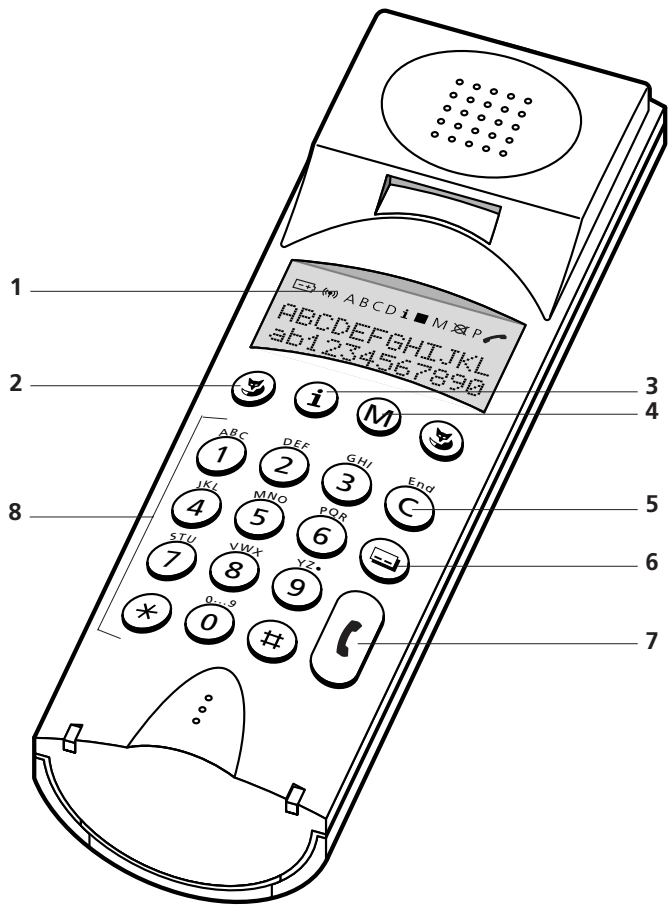

# Operation and display elements

## 1 Display

The display consists of 3 lines of text, each with 12 symbols/characters. The first line consists only of symbols, the two others consist of information or menu options.

## 2 Foxkeys

The current function is indicated in the bottom display line. Both Foxkeys are freely programmable.

## 3 i-key (information key)

Pressed to obtain further information (active i-symbol)

## 4 M-key (menu key)

This key is used to search for a menu option you desire. It operates cyclically, i.e. each depression of the menu key will scroll you through the menu options.

## 5 C/End key (deletion or correction key)

Deletion or correction key (clear).  
Return to previous menu option or to the idle state.

## 6 Hotkey

Freely-programmable key for up to 6 numbers/names or functions

## 7 Call key

Has the same effect as lifting or replacing the handset of a corded terminal.  
Also used for switching on the handset.

## 8 Keypad with 0 to 9 (A to Z), \* and #

Used for entering characters, selecting extended-feature functions utilising \*/# procedures. Input of names and/or texts in alpha mode. (Automatic switchover from numeric to alpha input following selection of corresponding menu option.)  
Example: 1 x key 2 = D, 2 x key 2 = E, 3 x key 1 = C, 2 x key 7 = T

In alpha mode the #-key can also be used to create a space.



# Operation and display elements

## Special display symbols



Charge state of battery pack

Not displayed: Charge is ok, handset is ready for operation  
Blinking display: Charge is low (warning)  
Blinking + warning tone: Charge is very low



Antenna symbol

Not displayed: Outside of radio coverage range  
Continuous display: Ready for incoming and outgoing calls

A (B,C,D)

Continuous display: Handset is registered and ready for operation in system A (B, C, or D).  
Blinking: Handset is not ready for operation.

ABCD

Blinking: Handset is not registered in any system.

ABC

Continuous display: Alpha dial feature is activated

**i**

Supplementary information (accessed by pressing i-key)



A function stored under Hotkey/Foxkey is active

M

Further menus (trigger with M-key)



Microphone switched off

P

Programming mode



Continuous display: Connection made  
Blinking: Visual signal indicating a call always present!

Other symbols on the information or menu line:

- 12☒ Scrolling forwards through a list (the digit shows the entry's number)
- G Call for user group (internal subscriber group)
- D Diverted call
- f Function is active

Quality of the radio connection (only on idle display)

- Very good connection quality
- Good connection quality
- Telephone calls possible, interference probable
- Telephone calls possible only in part, severely restricted
- No telephone calls possible

**Note**

You can also obtain the connection quality reading using "Long Click 4". The number of the relevant radio unit is displayed at the same time.

# Operation: the menu system

You can program your new handset to meet your own requirements. Besides mobility, it offers you every telephony function you could wish for. The menu technique and the clever Foxkeys see to that. To make full use of the extended-feature functions, please refer to the chapter "How to program your telephone" and the special programming instructions.

## General rules of operation

There are two types of menus:











- Everyday operating menus for telephony functions.
- Programming menus for setting your telephone to meet your requirements.

**Display in idle state** In the idle state the display features a number of symbols, the quality indicator, the date and time as well as a personal standby text (e.g. name, dept., tel. No., etc.). The display immediately switches to "Discreet" or to "Enqui" "Micro" if a call comes in or during a call.

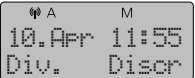
—> —> —> Press the M-key (briefly once or several times) to proceed to the menu option you desire.

—————> A "Long click" of the M-key (at least 2 seconds) takes you to the programming mode.

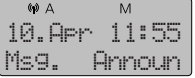
—————> A "Long Click" on the Fox-key under "⚡" changes the search direction in "⚡".

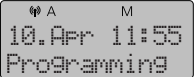
	Idle state Call up the desired menu using the M-key	
	Press M-key once	
	Press M-key a second time	
	Press M-key a third time	
	Press M-key a fourth time	
	Press M-key a fifth time	

## Safety advice

Read this operating instructions booklet carefully and keep it in a safe place. Please make a thorough study of the safety advice presented here. Not following these guidelines may be hazardous and may violate existing laws.

### Medical devices



Your telephone should not be used near pacemakers, hearing aids or other personal medical devices of this type.

### Availability of service



The base network is not always available. Do not depend on a mobile phone as your only means of communication in critical situations.

### Ambient conditions



Only use your telephone in a temperature range from +5°C to approx. +35°C. Avoid exposing it to direct sunlight and other heat sources.



Protect your telephone from moisture, heavy dust, aggressive liquids, and vapors. Do not place your telephone near electromagnetic fields (electrical motors, household appliances). The voice quality could be reduced. Avoid positioning it close to computers, radios, TVs, video players and phones, in order to avoid noise during a call .



Do not use your telephone in areas where there is a risk of explosions.



Do not use your telephone in areas where blasting work is going on. Observe the restrictions and follow the pertinent regulations.

### Maintenance and repairs



Use original accessories only. Call on an expert to do installation and repairs. Never touch the recharging contacts with optioned, metallic and/or greasy objects.

Clean your telephone with a soft, slightly moist or antistatic cloth. Do not use cleaning solvents or other chemical substances.

# Safety advice

## Important information

There is a constant code exchange between radio base and handset to ensure that no one with another handset can telephone at your expense. If the codes do not match, the call is disconnected or no connection is established.

## Locking the keypad

Your handset can be locked to prevent the accidental activation of keys. You can still receive calls using the Call key. The keypad must be unlocked before outgoing calls can be made.

## Changing the code/password

When the handset is turned on for the first time, the code/password is "0000". We recommend that you immediately programme a personal code consisting of 2 to 10 digits so the personal settings of your handset and the data stored in it are protected from unauthorized use.

## Batteries

Two rechargeable NiMh batteries, type AA, are delivered along with your telephone.

- Using other types of batteries or non-rechargeable batteries/primary cells may be hazardous and could cause your phone to malfunction or be damaged.
- Always insert the batteries in the correct position!
- Do not immerse batteries in water or throw into a fire.
- Use only the plug-in power supply delivered with the telephone for the charging base.
- The batteries must be charged for at least 9 hours without interruption before being used for the first time.

## Notes

- Batteries may become warm during charging; this is normal and perfectly safe.
- It takes several days for batteries to reach their full capacity and thus the full standby and calling time.

After a prolonged period of non-use as a result of a power shutoff (e.g. while you are on holiday), the handset (i.e. the batteries) should be recharged prior to being used again. Please dispose of defective batteries correctly (they are not household refuse).

# Installation and putting into service

## Contents of package

The following items are included with your telephone in the package:

- Charging base
- Handset
- Clip
- 2 batteries
- Plug-in power supply
- Operating instructions booklet

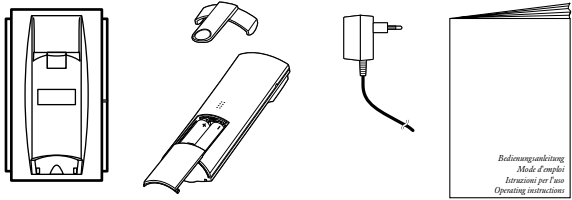

## Connecting the plug-in power supply

Feed the cord through the channel, placing it under the tabs so it cannot be pulled out.

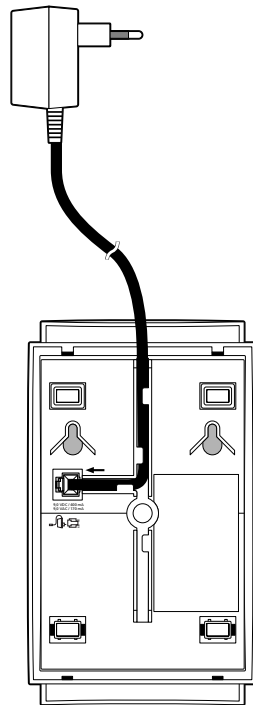

# Installation and putting into service

## Table/desk or wall installation, as you wish

### Table/desk installation

It is easiest to use the charging base as a table/desk unit. Simply place it at the desired location and connect it.

### Wall installation

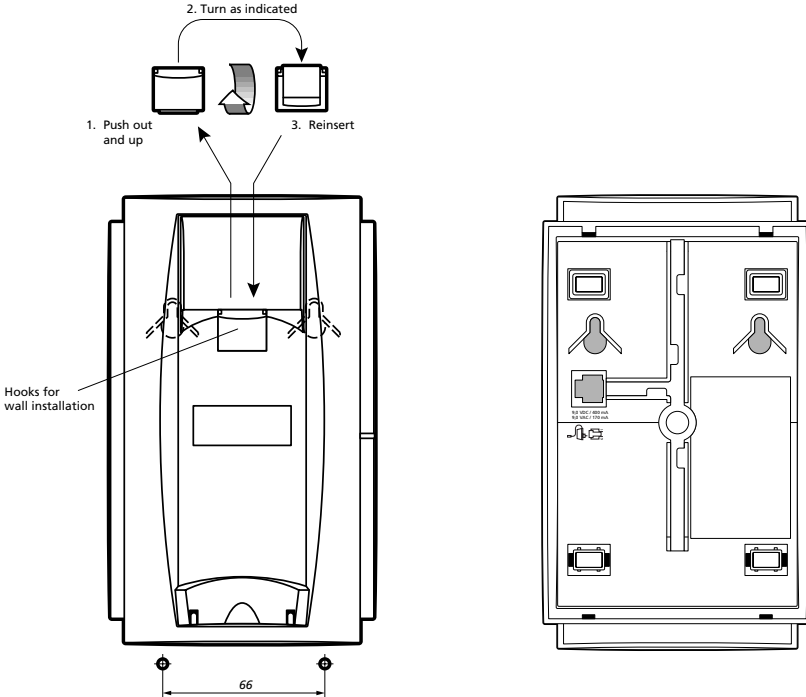

1. Turn the wall installation hook in the charging base by 180° (as shown in figure).
2. Switch the feet on the underside of the charging base (high feet at bottom of base) so the charging base hangs parallel to the wall.
3. Drill two holes (5 mm in diameter), spacing them 66 mm apart from each other.
4. Insert the wall plugs.
5. Screw in both screws until the heads are approx. 5 mm from the wall.
6. Mount the charging base in place and then pull down to locate in keyholes.

# Installation and putting into service

## Installation and charging of battery packs in handset

### Installing the batteries

1. To remove the cover of the handset battery compartment, apply gentle pressure to it and push it downward.
2. Insert the two batteries in the compartment as indicated in the figure. Make sure the poles are placed as shown in the compartment.
3. Slide the cover to the handset battery compartment over the batteries until it snaps audibly into place.

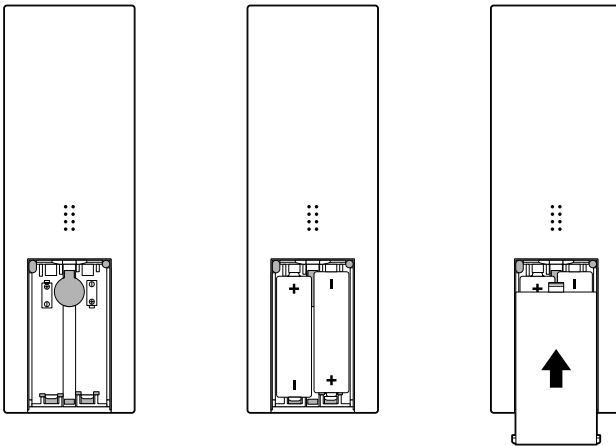

### Charging the batteries

The batteries are delivered uncharged. To charge them, place the handset in the charging base.

The green LED on the charging base displays the state of the batteries

- blinking = The batteries are being charged
- on (solid) = The batteries are charged

One battery charge

(1100 mAh-NiMh) lasts;

for approx. 60 hours of standby or

for approx. 8 hours of talk time

Charging takes

approx. 9 hours.

### Note

"Long Click 6" can be used to display the battery type and the charge state. When you replace the batteries it takes approx. 10-15 minutes of charging time to obtain a reliable indication of the charge state.

# Before you telephone for the first time

## Setting the display language

The language spoken in the area is usually preset in your handset. If you prefer another one, you can select among several different languages.



Press the M-key repeatedly in programming mode until, " \*Language " appears. (look for the " \* " symbol with a foreign language). Press the Foxkey under " \*Language ". By pressing the Foxkey under " \* " select the desired language.



Confirm the selected language by pressing the Foxkey under "Ok ". Press the C/End key to return to the standby display.

## Register the PBX system

You can register your handset for as many as 4 different PBX systems (A, B, C, D). So, you can be reached on your handset even while you are at a branch of your company.



Press the M-key repeatedly in programming mode until "System " appears. Then press Foxkey under "System ". "Auto" or the current system (A, B, C, or D) will appear in the display.



Press the M-key. If "Register: A " and "Delete " appear, the handset is registered with PBX system "A " (this registration could be canceled by pressing the Foxkey under "Delete ").



Using the Foxkey under " \* ", the handset can be registered with another three PBX systems (B, C or D). The display then changes to "Register: B (C or D) " and "New ". Pressing the Foxkey under "New " and "Home " causes the handset to be registered in system "B " (provided this is allowed and the system is available).

# Before you telephone for the first time



The handset can also be registered with a PBX system from a different manufacturer by using GAP (Generic Access Profile) and the required "Authentication code".

Press the Foxkey under "New" and "GAP". When "AC: \_\_\_\_" appears, enter the authentication code and acknowledge by pressing the Foxkey under "Ok".



## GAP log-on, compatibility with other DECT products

Ascotel DECT supports all the basic telephony features as defined in the Generic Access Profile (GAP) standard (end 1997 version). They include setting up and clearing down outgoing and incoming calls, inquiry call, DTMF and \*/# procedures. In other words:

- You can log on and use your DECT system terminal on a third-party PBX. The only requirement to be able to use all the basic features defined in the GAP standard is that they are fully implemented on the relevant PBX.
- Third-party DECT handsets that comply with the GAP standard can also be logged on to and used on your system. However, they will provide only the functionality limited by the GAP standard and not the same quality of radio connection. In particular the software for Mobility Management with handover/roaming is virtually fully dependent on the handsets used and cannot be adapted 100% to your system.

## Setting the PBX system



Press the M-key repeatedly in programming mode until "System" appears. Then press Foxkey under "System". "Auto" or the current system (A, B, C, or D) will appear in the display.



Select the desired system or „Auto“ with the Foxkey under "❖" and confirm by pressing "Ok". (If more than one system is available, and "Auto" is selected the handset automatically establishes a connection with the system that offers the best radio connection.)

## Notes

- With "Long Click 1" (min. 2 seconds) you can switch your handset over to the next available PBX system (A, B, C or D). Provided the switchover is not set on "Auto", manual switchover of the PBX system is compulsory to ensure that your handset is ready to operate in the new PBX system.
- "Long Click 2" is used to display the International Portable Equipment Identity (IPEI) and PARK (Portable Access Right Key).
- "Long Click 5" displays the software version number of the handset along with the date.

# Telephoning

## Answering an incoming call

An incoming call is signalled on the handset.



If the handset is not in the charging base, simply press the Call key to answer the call.

Or

The handset is in the charging base. The call can be answered directly by lifting the handset (see "How to program your telephone", "Direct seizure").

## Pick up a call

Under "Pick\_up" the system offers you "Sub" (Subscriber), "Bell" (Central bell with coded ringing) and "Page" (paging system).

To answer for instance a call directed to a terminal of a absent subscriber, press the M-key repeatedly until "Pick\_up" appears, press the Foxkey at this position and enter the subscriber number of the called terminal.

## During the call

During a call, you can use the M-key to execute other functions, for example, initiating an enquiry call, muting the microphone ("Mic mute"), switching the volume on the receiver from "Quiet" to "Loud" (or vice versa)



Press the M-key once or twice in order to execute other functions.

## Ending a call

A call is ended by pressing the Call key or by returning the handset to the charging base. Of course, the party you are talking to can also end the call. The handset returns to idle state shortly afterwards.

## Adjusting the receiver volume during a call

If you are having difficulty understanding a caller because of the background noise, you can switch the volume to "Loud".



Quiet



Loud



Press the M-key repeatedly until "Loud" appears. Press the Foxkey under "Loud".

## Note

The new setting is retained until changed back.

# Telephoning

## Dialling with dialling preparation

Dialling preparation reduces the chance of misdialling. Without pressing the Call key beforehand, enter the desired number, check it and make any corrections using the C-key. Then press the Call key. It is only at this point that the number is dialed.

## Dialling using digits

This is just like traditional dialling, but dialling is not commenced until you press the Call key.



Enter digits and press the Call key.

## Dialling using repeat dialling function (redial)

The numbers and the names of up to the last 10 subscribers called are stored in the "Last Number Redial" memory.



Redial



Press the M-key.  
Press the Foxkey under "Redial". The display shows the number and possibly the name of the last subscriber called.



Press Foxkey under "\*" until the number of the desired subscriber appears. Press the Call key.

## Note

The i-symbol refers to additional information, which you can call up by pressing this key.

## Dialling using the Hotkey

You can store up to 6 names/numbers of frequently called subscribers in the Hotkey memory.



Press the Hotkey repeatedly until the desired name is displayed.

Mike



Press the Foxkey under the desired name and then press the Call key.

# Telephoning

## Dialling with a name from a directory

There are up to three telephone directories: an internal directory (with all subscribers connected to PBX), a directory containing abbreviated dialling numbers, and a private directory. The desired call can be made with the subscriber name without having to enter his or her number.

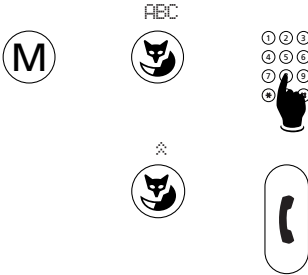

Press the M-key. Press the Foxkey under ABC; the menu for selecting the directory appears. ("All" runs a search in all directories). Enter the initials of the surname and first name, - e.g. E # A for Einstein Albert.

Press the Foxkey under "☼" to scroll to the desired name and press the Call key to initiate dialling.

### Note

Entering initials is the simplest way of dialling a number stored in the index; you do not need to know either the phone number or the abbreviated dialling number.

Example:

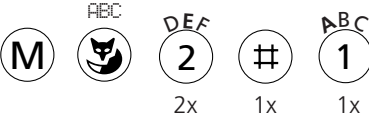

Einstein Albert:  
Key 2: twice  
# key: once (generates a blank)  
Key 1: once

If you only know the surname:



Correct numbers or names entered in dialling preparation using the correction key (deletes last character).



A "Long Click" of the C-key ends the call preparation.

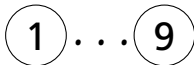







Needless to say, you can also dial the old-fashioned way with your handset by simply pressing the Call key and dialling the number.

If you wait more than 10 seconds between digit inputs, dialling is automatically terminated.

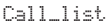
# Telephoning



## Call list



Your handset automatically stores the numbers of the last 10 unanswered calls in the call list. The i-symbol in the display draws your attention to the unanswered calls. You can check these numbers and use this list to call back the corresponding persons.

				Keep pressing the i-key until "Call_list" appears. Press the Foxkey under "Call_list" and scroll to the desired number with the Foxkey under "❖".
			Press the Call key to call the number in the display. Pressing the Foxkey under "Delete" deletes the entry from the call list.	

## Switching off the microphone (Mute)

If you wish to speak for a moment to somebody else in your office without the person on the telephone listening in, you switch off the microphone of your handset.

		Press the Foxkey under "Microphone". The microphone is switched off. (The following symbol appears in the display: "⊗").
		

		Press the Foxkey under "Microphone" again, the microphone is switched back on again and the "⊗" symbol is removed.
		

## Switching on the discreet ringing feature

During a meeting a call to your handset can be intrusive. When the discreet ringing feature is activated, the handset beeps just once to signal a call. You can identify the caller by the name on the display and decide whether you want to answer the call. If you decide not to, his/her number is entered in the call list. The i-symbol on the display will remind you of this later. The discreet ringing feature remains activated until it is cancelled. This i-symbol on the display also reminds you of this fact.

			Press the M-key repeatedly until "Discreet" appears. Press the Foxkey under "Discreet".
			

## Note

The discreet ringing feature can also be switched on during a call. The menu option "Discreet" appears on the display in conjunction with each call. The ring (only the ringing itself, not the actual call) is switched off as soon as the discreet ringing is switched on.

# Using the extended-feature functions

## Switching off the discreet ringing feature



Reset

Press the i-key repeatedly until "Discreet" and "Reset" appears in the display.

Press the Foxkey under "Reset" and the discreet ringing feature is switched off.

## Parking a call

During a conversation, you may hear a "Call waiting" tone indicating that another subscriber is trying to call you. If you answer the call, the connection with the first person you were talking to is put on "Hold". Before you can transfer the second connection, you must "Park" the connection which is on hold.

2. \_conv



Park



Press the Foxkey under "2nd conversation" to re-establish the connection to the caller on hold.

Press the M-key repeatedly until "Park" appears.

Press the Foxkey under "Park" to park the current connection.

2nd\_convers.



Press the Foxkey under "2nd conversation" to

switch to the second caller. You can now transfer the call.

Take\_back



Press the Foxkey under "Take back" to re-

establish the connection with the waiting caller.

## Note

Parking requires no channel, unlike a connection on hold where both call channels are busy. The advantage of this is that you can transfer the "call waiting" party (if necessary). If [P] appears, a call is already parked.

## Brokering

After initiating an enquiry call, you can return to the first caller without ending the enquiry call connection. Afterwards, you can then switch back and forth between the two subscribers as many times as you wish (brokering).

2. \_conv



Press the Foxkey under "2nd conversation" to switch to the first caller.

2. \_conv



Press the Foxkey under "2nd conversation" to switch back to the enquiry call subscriber, etc.

(and repeat this as often as desired or necessary).

# Using the extended-feature functions

## Transferring a call

After initiating an enquiry call, you can connect your two callers with each other directly.



Press the Call key, your handset automatically reverts to idle state.

## Conference

You have an enquiry call on the line and would now like to conduct a joint conference call with your original caller (3-way).



Press the M-key and then the Foxkey under "Conference".

## Note

There is no need to worry about calls being disconnected when you set up the conference call. The only way calls are disconnected is when the C-key or the Call key is pressed.

## Call diversion

You can divert calls to another telephone or to the switchboard unit or leave a message for callers.



Press the M-key repeatedly until "Diversion" appears and then press the Foxkey under "Diversion". Press the Foxkey under "\*" to select the diversion type (i.e. "Div. on busy" or "Fwd. to Sub.").



Dial the diversion target and if necessary the new number. Confirm with "Ok".

## Note

If you only want calls to be diverted when you are busy with another call, select "Div. on busy".









## Twin Mode (present/absent)

If you have a stationary set along with your handset, Twin Mode is an easy way to make sure you can always be reached. When Twin Mode is programmed (see "Programming your telephone"), call diversion is automatically activated as soon as you remove the handset from the charging base.

# Using the extended-feature functions

## Leaving a message

You leave your workplace (without your handset) and wish to leave any callers a message.

- |   |   |   |  |
|---|---|---|--|
|  |  |  | Press the M-key repeatedly until "Diversion" appears. Press the Foxkey under "Diversion" and then under "☼" until "Div. to Msg." appears in the display. |
|   |  |  | Press the Foxkey under "Ok" and repeatedly under "☼" until a suitable message appears (i-symbol on the display).   |
|   |   |  | Press the i-key once or several times to display the entire message.   |
|  |  |  | Edit the message using the C-key and the alphanumeric dialling keypad (if necessary, see "Dialling with a name"). Press the Foxkey under "Ok".           |



### Note

If you wish, you can also delete the entire message with the C-key and write your own.

## Call back requested (calling back)





A subscriber has an important message for you and was unable to reach you despite your having a handset. He/she requests a call back.

"Call back" and "Call" "Delete" appears on the display of your handset.

- |   |   |  |
|---|---|--|
|  |  | Press the Foxkey under "Call" to return the call or under "Delete" if you think it no longer necessary to return the call. |
|---|---|--|

## Paging

To page a person directly or after trying to phone.

- |   |   |   |  |
|---|---|---|--|
|  |  |  | Press the M-key repeatedly until "Page" appears. Press the Foxkey at this position, enter the number of the person sought and confirm with "Ok". |
|   |  |   |  |

# Using the extended-feature functions

## Requesting a callback

You request a call back from an internal subscriber whose line is busy or who is not answering.

C\_back



Press the Foxkey under "Call\_back". The message "Call expected from the number nnn" appears in the display.

Reset



By pressing the Foxkey under "Reset" you can cancel the requested call back.

### Note

Only one call back can be activated at a time.

## Sending a message

Standard messages are stored in the PBX. After failing to reach a subscriber, you can select one of these messages, add to it or change it if necessary and then send it to the subscriber or a group you are trying to reach.



Msg.



Press the M-key repeatedly until "Message" appears. Press the Foxkey under "Message". Press the Foxkey repeatedly under "i" until a suitable message appears (i-symbol on the display).



Press i-key once or several times to display the entire message.



Edit the message using the C-key and the alphanumeric dialling keypad (if necessary, see "Dialling with a name"). Press the Foxkey under "Ok".



Dial the number of the subscriber/the group to whom the message is directed. Press the Foxkey under "Ok" to send the message.

### Notes

- This procedure can also be initiated with "Dialling preparation", i.e. enter the number first and then select the message.
- If you wish, you can also delete the entire message with the C-key and write your own.

# Using the extended-feature functions

## Read message

If you have received a message, the display will contain the word "Message" (the number of its sender can be seen if the i-key is pressed) and the menu options "Read" and "Delete".

Read



Press the Foxkey under "Read". The "+" sign indicates that more information is available.



Press the i-key to view the next line.

At the end of the message, the display switches to the initial menu options "Read" and "Delete".

Delete



Press the Foxkey under "Delete".

## Note

To display other messages you may have received, the messages already read must first be deleted.

## Announcement

You can make announcements to one or several internal subscribers from your handset, provided their system terminals have a loudspeaker.



Announ



Press the M-key repeatedly until "Announcement" appears. Press the Foxkey under "Announcement".



Group



Enter the desired subscriber number. (Or press the Foxkey under "Group" and enter the announcement group number.)

Ok



Press the Foxkey under "Ok" and make your announcement.

# Using the extended-feature functions

## Transparent mode (Tone dial mode DTMF)

During a call connection the tone dial mode can be used to activate a function such as, for example, the remote control of an answering machine.



"Long Click" of the \* key until "Tone dial" appears. Enter the character sequence of the desired function.

After carrying out this procedure:



Press the C-key to switch the tone dial mode off again

or



Press the Foxkey under "Reset".

## Beginning and ending enquiry calls

The caller you are talking to on the telephone asks a question you cannot answer. You wish to call a fellow employee for information, without cutting off your connection with the caller.



Enter the number of the subscriber you wish to call for the information.  
Press the Foxkey under "Enquiry"; the subscriber is called (while the other connection is put on hold).

After obtaining the information you needed:



Press the C-key to switch back to your call with the waiting caller.

### Note

If the Call key is pressed after an enquiry call, a continuous tone will sound for 10 seconds. Press the Call key while this tone is sounding to reconnect the handset to the waiting subscriber.

# Programming your telephone

## Points to consider when programming your phone

Programming is an integral part of the concept of operation. Before you start programming, read the chapter "Operation: The menu system" at the beginning of these operating instructions.

### Programming mode

You can advance to the beginning of the programming mode in one of two ways:

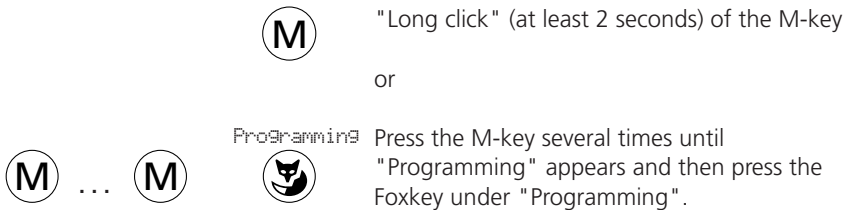

### Note

"Long Clicks" depend on the software and the PBX type.

### Menu key

With the Menu key (M-key) you can initially access all the programming parameters, once a parameter has been selected (e.g. Keys), the M-key is used to access the various options for the selected parameter, such as "Number key" etc.

You can exit either level by pressing the C/End key.

### Storing

The contents of a menu option you have programmed or changed yourself will be stored if you press the Foxkey under "Ok". If you press another key, the programming you have carried out will not be stored.

# Programming your telephone

## Overview

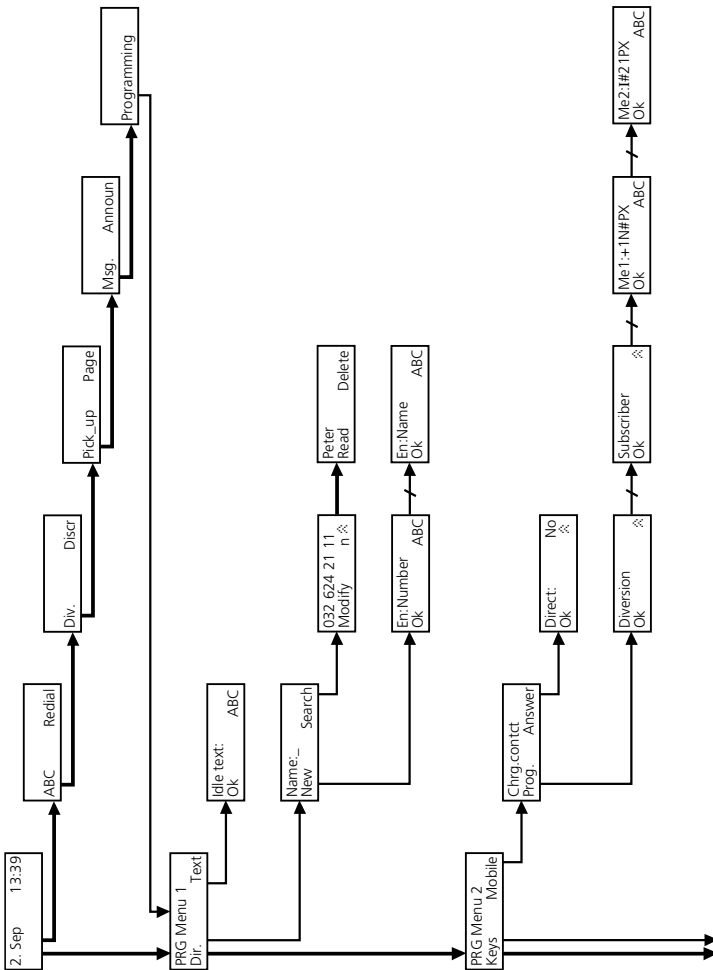

## Overview (continuation)

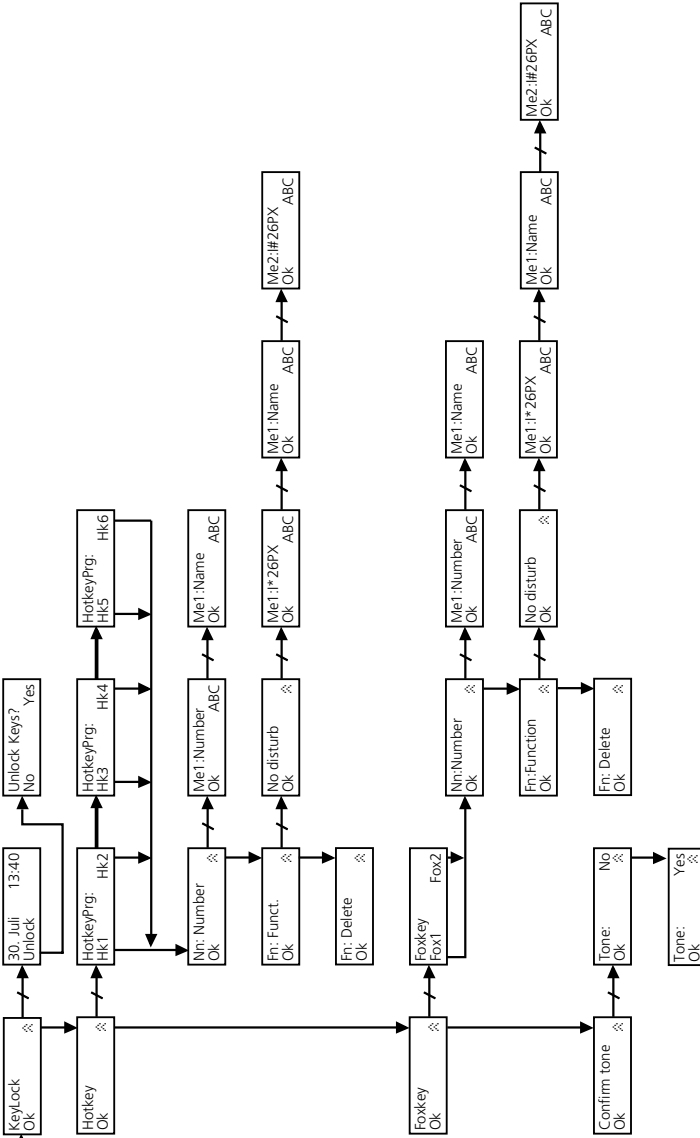

# Programming your telephone

## Overview (continuation)

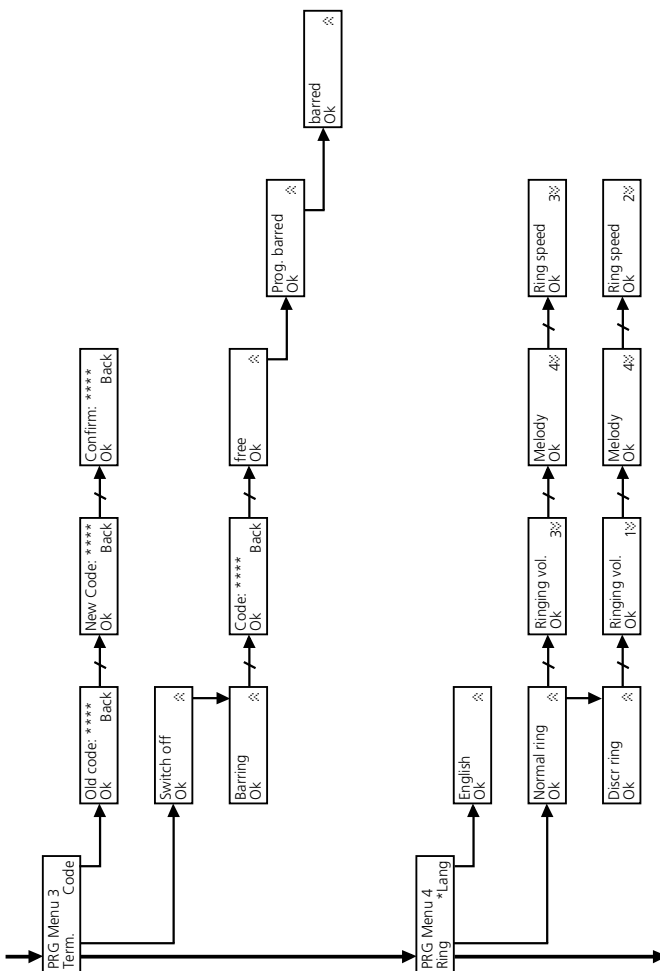

# Programming your telephone

## Overview (continuation)

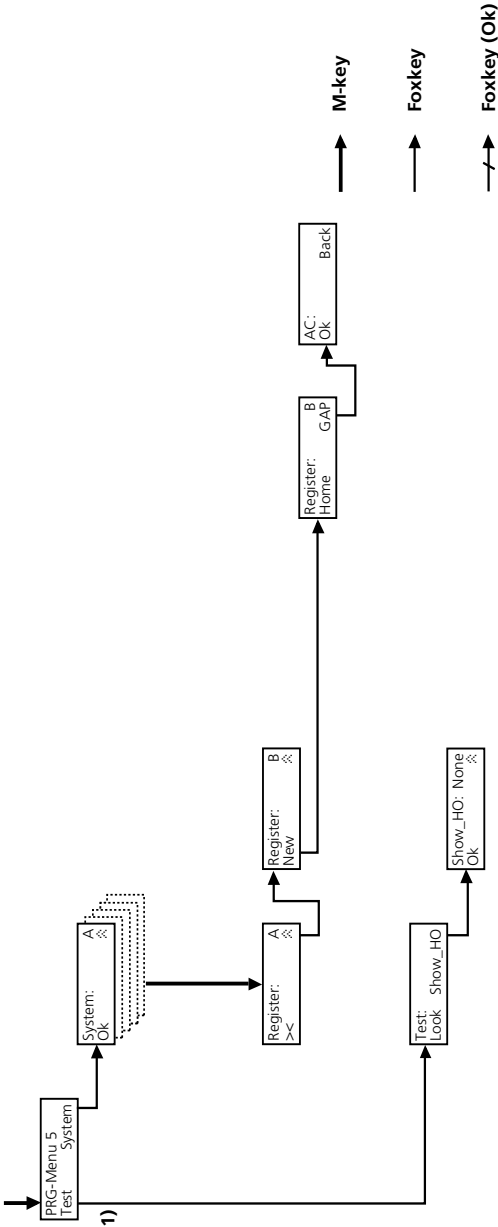

1) The menu point "Test" is reserved for the technician handling installation

# Programming your telephone

## Twin Mode (present/absent)

If you have a stationary set along with your handset, Twin Mode is an easy way to make sure you can always be reached.







The recharging contact acknowledges 2 states:

- a) Handset in charging base (present)
- b) Handset not in charging base (absent)





Based on these states automatic call diversion is executed as soon as the handset is taken out of the charging base.

After returning the handset to the base, the diversion is automatically switched off.

## Activating Twin Mode

-   **Mobile** In programming mode, keep pressing the M-key until "Mobile" appears. Press the Foxkey under "Mobile".
-    **Ok** Press the Foxkey under "Prog.", then use the Foxkey under "☼" to scroll to "Twin" and then confirm with "Ok".
-   **Ok** Under "TwinNo:" enter the access number of the corded terminal that is to be diverted to the handset. Activate Twin Mode with the Foxkey under "Ok".

## Deactivating Twin Mode

-   **Mobile** In programming mode, keep pressing the M-key until "Mobile" appears. Press the Foxkey under "Mobile".
-    **Ok** Press the Foxkey under "Prog.", then use the Foxkey under "☼" to scroll to "No function" and use the Foxkey under "Ok" to deactivate the Twin Mode.

## Notes

- If call diversion/call forwarding to secretary, voice mail or your own GSM set, etc., is intentionally activated on the corded terminal with the handset still in the charging base, that particular setting takes priority over Twin Mode, i.e. calls will not be automatically diverted to the handset when you remove it from the charging base. Twin Mode is reactivated as soon as the call diversion/call forwarding activated on the corded terminal is reset.
- Other functions besides Twin Mode can also be set (see "Mobile" programming instructions)

# Programming your telephone

## Private directory

In addition to the directories of available PBX subscribers and abbreviated dialling numbers, you can also set up a private directory with up to 30 telephone numbers and names. You can protect the entries from being accessed by unauthorized parties by barring the programming functions of your handset.



Press the M-key repeatedly in programming mode until "Directory" appears.

Dir.



Press Foxkey under "Directory" and then under "New" or "Search".

New



Ok



With "New", the next free directory entry is shown. Enter the number, acknowledge by pressing "Ok" and enter the name. Press the Foxkey under "Ok" to have the entry stored in memory.

Search



⌘



With "Search", you can use Foxkey under "⌘" to page to the desired entry.

Modify



Ok



Press the Foxkey under "Modify", change the stored entries, and then restore in memory by pressing the Foxkey under "Ok".

## Notes

- If a directory entry has been previously entered, the current entry details are displayed. You can of course edit it.
- We advise you to enter the name corresponding to each number; this enables you to use the convenient name dialling feature.
- If the number of the caller is displayed during a call (CLIP), the system looks for the number through all directories. If it is already stored with a name, this name is also displayed.

# Programming your telephone

## Macro language

The macro language allows you to store several functions in succession under one key.





I	Seizes line
X	Hangs up receiver (disconnect)
P	Pause (1 second)
N	Inserts the number entered/displayed in dialling preparation
*	Activates control key
Z	Switches Tone Dial Mode ON/OFF
R	Redials last number dialed

Examples:

I201	Seize and call internal subscriber 201
I*21201X	Seize, divert call to internal subscriber 201, and hang up receiver.

## Programming the text display for idle state

You can programme text string for the display in idle state instead of just displaying the time and date.

-  Press the Foxkey under "Text" in programming mode and enter text (maximum of 12 characters).
-  Press the Foxkey under "Ok" to store the input in the memory.
-  Edit the standby text (if necessary).  
The correction key (C/End) can be used to delete the characters to the left of the cursor.
-  After editing the standby text, press the Foxkey under "Ok".

### Note

A "Long Click" of the C/End key (min. 2 seconds) takes you straight back to the previous menu.

# Programming your telephone

## Locking the keypad

You can lock your keypad from accidental activation. Incoming calls are signaled and can be taken by pressing the Call key. Unlock the keypad prior to making outgoing calls. After the call you have 5 seconds within which to set up an outgoing call. The key lock (Variant 1) is reactivated after the 5 seconds.



Press the M-key repeatedly in programming mode until "Keys" appears.

Keys



Press the Foxkey under "Keys", "Keylock" appears.

Ok



Press the Foxkey under "Ok" to activate the "Keylock" feature.

"Unlock" appears on the display.

Unlock



Press the Foxkey under "Unlock". The handset asks you "Unlock keys?" to confirm that the keypad should be unlocked.

Yes



If you press "Yes", the standby display appears and the handset is ready again for operation.

## Notes









- "Long Click 8" (min. 2 seconds) can also be used to switch on Variant 1 of the key lock.
- "Long Click 9" can be used to switch on Variant 2 of the key lock. This variant is not automatically disabled when you receive a call and has to be disabled manually (see above) to be able to answer the call with the Connect key.

# Programming your telephone

## Programming the Hotkey

The Hotkey is a freely programmable key where up to 6 numbers/names or functions can be stored. You can even store whole operating sequences using the macro language.

### Storing numbers/names under the Hotkey

- |  |   |  |
|--|---|--|
|   | <br>Keys | Press the M- key repeatedly in programming mode until "Keys" appears.<br>Press the Foxkey under "Keys".  |
|   | <br>Ok   | Press the Foxkey repeatedly under "☼" until "Hotkey" appears. After pressing the Foxkey under "Ok" the strings "HotkeyPrg." and "Hk1", "Hk2" will appear.                |
|   | <br>Ok   | Press the M-key one or two times to call the memories "Hk3" and "Hk4" or "Hk5" and "Hk6", respectively.<br>Select the desired memory (Hk1...Hk6) by pressing the Foxkey. |
|  | <br>Ok   | Confirm again with "Ok" in the menu "Number : Nr."   |
|  | <br>Ok   | Enter the number, acknowledge by pressing "Ok" and enter the name.<br>Press the Foxkey under "Ok" to have the entry stored in memory.                                    |

### Note

The program jumps directly to the Hotkey Programming when you "Long click" the Hotkey.

# Programming your telephone

## Storing functions under the Hotkey

Same procedure as under Number/Name until it comes time to select the memory Hk1...Hk6. From that option:



Press Foxkey under "☼" to call the menu "Fn: Funct." (Function) and confirm by pressing "Ok".



Press the Foxkey under "☼" repeatedly until the desired function is displayed and confirm with "Ok".



The contents of memory 1 for this function are displayed (activate function). Press Foxkey under "Ok" to store the function in memory.



If desired, enter a name and acknowledge with "Ok". The contents of memory 2 are displayed (deactivate function).



The function is stored in memory using "Ok".

## Notes







- The corresponding function codes are entered in the two memory locations automatically and can be added to/amended as required.
- If you do not enter a name when storing, a short default name will be used, e.g. "DND" for "Do not disturb".
- The symbol "■" in the symbol line and a "⌄" next to the function indicate that a programmed function is active.
- The program jumps directly to the Hotkey Programming when you "Long click" the Hotkey.

# Programming your telephone

## Programming the Foxkeys

You can also use both Foxkeys as freely programmable keys. The display in standby mode contains very frequently used numbers or functions which can be conveniently dialled or executed by means of a single keystroke (of the corresponding Foxkey). If a function is stored under the Foxkey, its active state is indicated with the "f" symbol.

## Storing Numbers/names or functions under the Foxkey







	 Keys	Press the M-key repeatedly in programming mode until "Keys" appears. Press the Foxkey under "Keys".
	 Ok	Press the Foxkey repeatedly under "f" repeatedly until "Foxkey" appears.
		Press Foxkey under "Ok" and then select the desired key ("Fox1" or "Fox2").
Fox1 	Fox2 	Proceed as under "Hotkey programming."

### Notes

- A "Long click" of the Foxkey takes you directly to the Foxkey programming.
- The quality display disappears once both Foxkeys are occupied with a number or function and a name.
- The quality display is maintained if a blank character is entered with the #-key under Foxkey 1 or 2 instead of a name.

### Key confirmation tone

If you wish, the handset can confirm every keystroke with a short confirmation tone.

	 Keys	Press the M-key repeatedly in programming mode until "Keys" appears. Press the Foxkey under "Keys".
 f	 Ok	Press the Foxkey repeatedly under "f" until "Confirmation tone" appears and confirm with "Ok".
 f	 Ok	Press the Foxkey repeatedly under "f" to select "Tone: Yes" or "Tone: No". Press Foxkey under "Ok" to store the setting

### Note

Whenever you place the handset into the charging base, a short tone always sounds to confirm this action.

# Programming your telephone

## Direct answer

If the handset is set at "Direct" answering, you can answer incoming calls automatically by simply taking the handset out of the charging base. You need not press the Call key.

Returning the handset to the charging base always causes a connection to be ended unless this was already done by pressing the Call key.



Mobile



Answer



Press the M-key repeatedly in programming mode until "Mobile" appears, press the Foxkey under "Mobile" and then under "Answer".



Ok



Press the Foxkey under "\*" to switch to "Direct: Yes" and confirm this setting by pressing the Foxkey under "Ok".

## Switching handset (terminal) ON/OFF

### Switching OFF



Press the M-key repeatedly in programming mode until "Terminal" appears.

Term.



Press the Foxkey under "Terminal"; "Switch off" will appear.

Ok



Press the Foxkey under "Ok" to switch off the handset.

The connection to the radio base is terminated (display is empty).

### Notes

- You can also switch off the handset with a "Long click" (at least 2 seconds) of the 0 (zero) key.
- If you are outside the range for radiocommunications, the handset will make repeated attempts to establish a connection with a radio base. If you plan on being out of range for an extended period, switch off the handset to save your battery.

### Switching ON



Press the Call key and switch on the set with the Foxkey under "Yes".









# Programming your telephone

## Barring and unbaring your handset (terminal)

You can protect your handset from being used by unauthorized persons. Your system manager can tell you which numbers (for example, emergency numbers) can be dialled whilst your handset is barred.









When your handset is barred, you can still answer incoming calls at any time by pressing the Call key. The handset must be unbarred before an outgoing call can be made.

It is recommended that you bar the programming functions of your handset using "Prog.: barred". This protects the entries in your private directory, among other data.

		Press the M-key repeatedly in programming mode until "Terminal" appears and press the Foxkey under "Terminal"; "Switch off" will appear.	
			Use the Foxkey under "❄" to select "Barring"; press "Ok" and enter the code (password).
			Press the Foxkey under "Ok" to verify the password.
			Press the Foxkey under "❄" to select "free", "Prog.barr" (Programming barred) or "barred" ("free" cancels the barred state) and confirm with "Ok".

## Changing code/password

The first time you switch on your handset the code/password is set at "0000". It is recommended that you immediately reprogramme a personal password of from 2 to 10 digits to protect the personal settings in your handset and the data stored from unauthorized use (change, deletion).









			Press the M-key repeatedly in programming mode until "Code" appears. Press the Foxkey under "Code" and enter the current code.
			Press the Foxkey under "Ok" and enter the new code.
			Press the Foxkey under "Ok"; "Confirm" will appear. Enter the new code again and confirm with "Ok".

# Programming your telephone

## Adjusting ringing signal and setting the discreet ringing feature

Your handset can signal a call with different volumes, ring melodies, and speeds. You select the version you like best. These features make it easier for you to distinguish whether a call is for you or possibly for a person nearby.

When the discreet ringing feature is activated, your handset sounds just a single ring tone.

- |   |   |   |
|---|---|---|
|   |  | Press the M-key repeatedly in programming mode until "Ring " appears.   |
|  |  | Press the Foxkey under "Ring " and then use the Foxkey under "⚡" to select "Normal ring" or "Discr ring".   |
|   |  | Press the Foxkey under "Ok" to activate the current ring signal.  |
|   |  | Press the Foxkey repeatedly under "⚡" until the desired volume is reached.  |
|  |  | Press the Foxkey under "Ok" to store the setting and in the next menu, use the Foxkey under "⚡" to select a melody.   |
|  |  | After storing the melody by pressing "Ok", press the Foxkey under "⚡" in the "Ring_speed" menu in order to set the desired ring speed; then confirm with the Foxkey under "Ok". |

### Note

You can use the M-key to scroll between the menu options "Ringing\_vol.", "Melody" and "Ring\_speed" without having to make any changes.

# Troubleshooting

## Leaving the radio coverage area

You will hear a warning tone if you are about to leave the area of radio coverage. Once you have left the area the message "No System" will appear and the aerial symbol "📶" will disappear.

If during a call you move out of range completely, your call will be interrupted but the connection will not be cleared down immediately. The system will then attempt for around 20 s to set up a new radio connection with the same - or another - radio unit. Only then will the connection be cleared down in the PBX.

Outside radio coverage range, you have the following M-key programming functions at your disposal:

"Prog.", "Keys", "Mobile", "Term.", "Ring", "\*Language", "Test" and "System".

## Display showing but no connection

The handset may be barred (see "Barring/unbarring handset").

## The Hotkey and/or Foxkey cannot be programmed

Programming may be barred (see "Barring/unbarring handset").

## Unbarring the handset if password is forgotten

Ask the system manager to unbar your handset and default the password to "0000".

## Special display contents

### "Please wait"

This message may appear during the registration procedure. It also appears when a caller puts the call on hold.

### "Handset unknown"

The registration of the handset with the PBX system has failed. Please contact the system manager.

### "Overload"

No free resources, please wait and try again.

### "System Busy"

Temporarily, calls cannot be set up via the current radio unit. The handset is trying to establish a better radio connection with the same - or another - radio unit. The message appears only in the idle state.

### "No System"

You are out of radio coverage range; the connection with the PBX system was broken off.

### "Registration"

The registration procedure on the PBX system is in progress.

### "Defective" / permanent progressive ringing

Each time the handset is placed on the charging box, its parameters are checked. If a parameter error is detected, you will hear an acoustic fault signal and the display will read "Defective". The handset must then be sent back to the supplier for repairs/replacement.

## Note

If other messages appear, ask your system manager about them.

# Function codes

## Which prefix code numbers to dial

Standard dialling	Key sequence
<b>Abbreviated dialling numbers generally PBX</b> .....	7000...7999 <sup>1)</sup> .....
<b>Door intercoms</b> .....	851... 852 <sup>1)</sup> .....
<b>Emergency codes</b> .....	12 .....
<b>External line</b>	
business .....	0 .....
private .....	10 .....
to include cost centre code .....	13 CC no. ....
<b>Routing codes</b> .....	170... 199 <sup>1)</sup> .....
<b>Switchboard attendant</b> .....	11 .....
<b>User group codes</b> .....	860... 888 <sup>1)</sup> .....

## Suffix dialling

<b>Brokering</b> (switching between two connections) .....	2
<b>Call back</b>	
activate while subscriber is busy .....	9 or *37
activate while subscriber is free .....	9 or *37
<b>Call back req. no. / MESSAGE</b>	
activate .....	*38
<b>Call waiting</b> .....	6 or *43
reject .....	0
answer with hold .....	2
answer without hold .....	1
answer with conference .....	3
<b>Coded ringing</b>	
activate .....	8 or *81
<b>Conference</b>	
establish from connection .....	3
exclude internal subscribers .....	*31
<b>Intrusion</b> .....	7 or *44
reject .....	0
answer with hold .....	2
answer without hold .....	1
<b>Paging system on</b> .....	8 or *81

1) The definition and the number range are software and PBX dependant

## Function codes

Re-booking ongoing call to cost centre number .....	*78 CC no.
Parking a call .....	*76
Transfer call .....	1

### Prefix dialling

---

#### Announcement

to a single subscriber .....	*7998 subs. no.
to a group .....	*79 group no.
answer announcement to a group .....	*89

**Answer circular call** ..... \*83

#### Appointments reminder call (wake-up call) <sup>2)</sup>

activate standing order .....	*56 hh mm
cancel standing order .....	#56
activate one-off order .....	*55 hh mm
cancel one-off order .....	#55

#### Call back req. no. / MESSAGE <sup>2)</sup>

activate .....	*38 subs. no.
cancel (target terminal) .....	#38 subs. no.

#### Call diversion

suppress incoming <sup>2)</sup> .....	*02
enable incoming <sup>2)</sup> .....	#02
activate unconditional <sup>2)</sup> .....	*21 dest. no.
cancel unconditional <sup>2)</sup> .....	#21
activate to most recently defined subs. no., uncond. ....	*21#
cancel to most recently defined subs. no., uncond. ....	#21
activate to pre-defined subs. no. <sup>2)</sup> .....	*22
cancel to pre-defined subs. no. <sup>2)</sup> .....	#22
activate when busy <sup>2)</sup> .....	*67 dest. no.
cancel when busy <sup>2)</sup> .....	#67
activate to most recently defined subs. no., when busy .....	*67#
cancel to most recently defined subs. no., when busy .....	#67
activate to standard text <sup>2)</sup> .....	*24 text no.#
cancel to standard text <sup>2)</sup> .....	#24
activate to pager or circular call with ring code <sup>2)</sup> .....	*28
cancel to pager or circular call with ring code <sup>2)</sup> .....	#28

#### Call forwarding (automatic call transfer if no answer)

suppress incoming <sup>2)</sup> .....	*02
enable incoming <sup>2)</sup> .....	#02
activate <sup>2)</sup> .....	*61 dest. no.
cancel <sup>2)</sup> .....	#61
activate to most recently defined subs. no. ....	*61#

<sup>2)</sup> Remote control possible

# Function codes

cancel to most recently defined subs. no. ....	#61
activate to pre-defined subs. no. <sup>2)</sup> .....	*62
cancel to pre-defined subs. no. <sup>2)</sup> .....	#62
activate to pager or circular call with ring code <sup>2)</sup> .....	*68
cancel to pager or circular call with ring code <sup>2)</sup> .....	#68

**Call pick up** ..... \*86 subs.no.

## Call waiting indication <sup>2)</sup>

suppress incoming .....	*04
enable incoming .....	#04

**Cancel call back** ..... #37

## Code call

activate .....	*81 subs. no.
answer .....	*82

## Conference

variable .....	*71 subs. no. 1*
	... subs. no. 5# <sup>1)</sup>
pre-defined .....	*70 conf. no

## Connection

park .....	*76
recall parked .....	#76

## Courtesy Service

switch on group 1 .....	*931
switch off group 1 .....	#931
switch on group 2 .....	*932 <sup>1)</sup>
switch off group 2 .....	#932 <sup>1)</sup>

## Day, night, weekend answer connection (Switch group 1)

day (Position 1) .....	*8511
night (Position 2) .....	*8512
weekend (Position 3) .....	*8513

**Deactivate all activated services <sup>2)</sup>** ..... \*00  
(except user group)

## Do not disturb (station guarding) <sup>2)</sup>

activate .....	*26
cancel .....	#26

## External line

activate with charge recall ..... \*32 subs. no.

1) The definition and the number range are software and PBX dependant

2) Remote control possible

# Function codes

## Follow me

activate .....	*23 subs. no.
cancel .....	#23

## Intrusion <sup>2)</sup>

suppress incoming .....	*04
enable incoming .....	#04

## Messages (standard messages with/without defined parameters) <sup>2)</sup>

send to a single subscriber .....	*3598 subs. no text no.#
send to a group .....	*35 group no. text no.#
broadcast .....	*3599 text no.#

## Open doors .....

\*751... \*752 <sup>1)</sup>

## Paging

page .....	*81 subs. no.
answer with one search path .....	*82
answer with multiple search paths .....	*82 subs. no.

## Relays

activate .....	*755... *757 <sup>1)</sup>
deactivate .....	#755... #757 <sup>1)</sup>

## Remote control

<b>activate</b> (from another set) .....	*06 subs. no. *21 dest. no.
activate remote control / enter remotely controllable number / enter desired *-procedure (e.g. *21 dest. no.)	

<b>deactivate</b> (from another set) .....	*06 subs. no. #21
activate remote control / enter remotely controllable number / enter desired #-procedure (e.g. #21)	

<b>deactivate</b> (from own set) .....	#21
enter #-procedure (e.g. #21)	

## Switch groups (incoming)

switch group x, pos. 1 .....	*85x1 <sup>1)</sup>
switch group x, pos. 2 .....	*85x2 <sup>1)</sup>
switch group x, pos. 3 .....	*85x3 <sup>1)</sup>
Note: x = 2 to 9	

## User group <sup>2)</sup>

join .....	*48
leave .....	#48

1) The definition and the number range are software and PBX dependant

2) Remote control possible

## A

- ABC 13
- Adjusting ringing signal 35
- Adjusting the receiver volume during a call 11
- Announcement 19

## B

- Barring and unbarrring your terminal 34
- Batteries 5, 8
- Brokering 15

## C

- Call diversion 16
- Call list 14
- Callback 17, 18
- Code/password 5, 34
- Conference 16

## D

- Dialling 12, 13
- Dialling with a name from a directory 13
- Direct answer 33
- Discreet ringing 14
- Display 1, 9
- Diversion 16
- DTMF 20

## E

- Enquiry calls 20

## F

- Foxkey 32

## G

- General rules of operation 3

## H

- Hotkey 12, 30, 31

## I

- Installation 6, 7, 8















## K

- Key confirmation tone 32

## L

- Leaving a message 17
- Leaving the radio coverage range 36
- Locking the keypad 29

## "Long Click" functions

-  Back to the previous menu 13, 28
-  Battery type and the charge state 8
-  Changes the search direction 3
-  Display IPEI 10
-  Foxkey programming 32
-  Hotkey programming 30, 31
-  Key lock (Variant 1) 29
-  Key lock (Variant 2) 29
-  Programming mode 3, 21
-  Quality of the radio connection 2
-  Select PBX system 10
-  Software version number and date 10
-  Switching off 33
-  Transparent mode 20

## M

- Macro language 28
- Message 18, 19
- Mute 14

## P

- Paging 17
- Parking a call 15
- PBX system 10
- Pick up a call 11
- Private directory 27
- Programming 21
- Programming the Foxkeys 32
- Programming the Hotkey 30, 31

## R

- Read message 19
- Receiver volume 11
- Redial 12
- Register the PBX system 9

## S

- Safety Advice 4, 5
- Sending a message 18
- Setting the display language 9
- Setting the PBX system 10
- Switching handset (terminal) ON/OFF 33
- Switching off the microphone 14

## T

- Text display for idle state 28
- Tone Dial Mode 20
- Transferring a call 16
- Transparent mode 20
- Troubleshooting 36
- Twin Mode 16, 26











*Office 20*



*Office 30*



*Office 40*



*Office 100*